

# ***XL4***

## **OPERATORS MANUAL**

Telex Communications (UK) Ltd,  
Klark Teknik Building,  
Walter Nash Road,  
Kidderminster.  
Worcestershire.  
DY11 7HJ.  
England.

Tel:+44 1562 741515  
Fax:+44 1562 745371

Website: [www.midasconsoles.com](http://www.midasconsoles.com)

MIDAS XL4 audio mixing console  
DOC02-XL4 Issue 1.0 - February 2005  
© Telex Communications (UK) Ltd.

In line with the company's policy of continual improvement, specifications and function may be subject to change without notice. This Operators Manual was correct at the time of writing. E&OE.





# MIDAS XL4 LIVE PERFORMANCE CONSOLE

## Contents

Introduction	
Features	
Overview and Statistics	
Technical Specification	
Block Diagrams	
Rear Panel	
Midas XL402 Input Pod	1
Midas XL401 Input Module	3
Midas XL405 Stereo Input Pod	7
Midas XL404 Stereo Input Module	9
Midas XL403 Input VCA Fader	13
Midas XL414 Group Module	15
Midas XL412 Group Pod	19
Midas XL413 Grand Master A VCA Fader	21
Midas XL421 Master Module	25
Midas XL422 Master Pod	29
Midas XL431 Communications Module	33
Midas XL441 Matrix Module	38
Midas XL443 Automation Central Control	41



## Introduction to the XL4

The XL4 was born out of a dream to design an analogue state of the art live mixing and recording console with unparalleled performance/features intrinsic with intuitive layout and operation. The vision required the analogue sound path to be controlled in the digital domain via a high degree of signal routing and moving fader automation enabling the live sound engineer whether in a touring or theatre production environment to utilise automation functions in order to enhance mix efficiency and performance to performance consistency.

The benchmark for the XL4 was the XL3 console which during production since 1990 gained a worldwide reputation for unequaled sonic performance and system transparency culminating in its award for best live sound mixing console 1993 and 1994.

Bob Doyle, Midas Sales & Marketing Director, spent ten months finalising the XL4 specification, discussing its concept with world class sound engineers and rental company heads as well as theatrical production designers and artists alike. The criteria was to develop a mixing environment which enhanced the creativity of the mixing engineer by automating the repetitive functions of specific mix and cue requirements, thus leaving he or she free to concentrate on the main thrust of live mixing by reproducing the Artist's music as it should be.

In our opinion, the XL4 combines all these criteria in a coherent, easy to operate mixing aid with unsurpassed sound and sonic quality.

Bob Doyle

Special thanks to:

Mick Anderson  
Chris Beale  
Tim Boyle  
Gary Bradshaw  
Lars Brogaard  
David Bryson  
Robert "Cubby" Colby  
Robert Collins  
Ralph Collins  
Alex Cooper  
Charlie Davies  
Keith Davies  
Steve Flewin  
Bryan Grant  
Chris Hill  
Paul Haseldine  
Rocky Holman  
Mick Hughes

Robbie McGrath  
Paul Newman  
Paul Owen  
John Penn  
Clay Powers  
Chris Rogers  
Ivan Schwartz  
Sophie Webster  
Mike Spratt  
Yan Stile  
Steve Sunderland  
Phil Wilkie  
Robin Whittaker  
Wladyslav Wygnanski  
Peter Ratcliffe  
Bob Goldstein  
Gottfried Duren-Fisgus  
Christian Gobbel

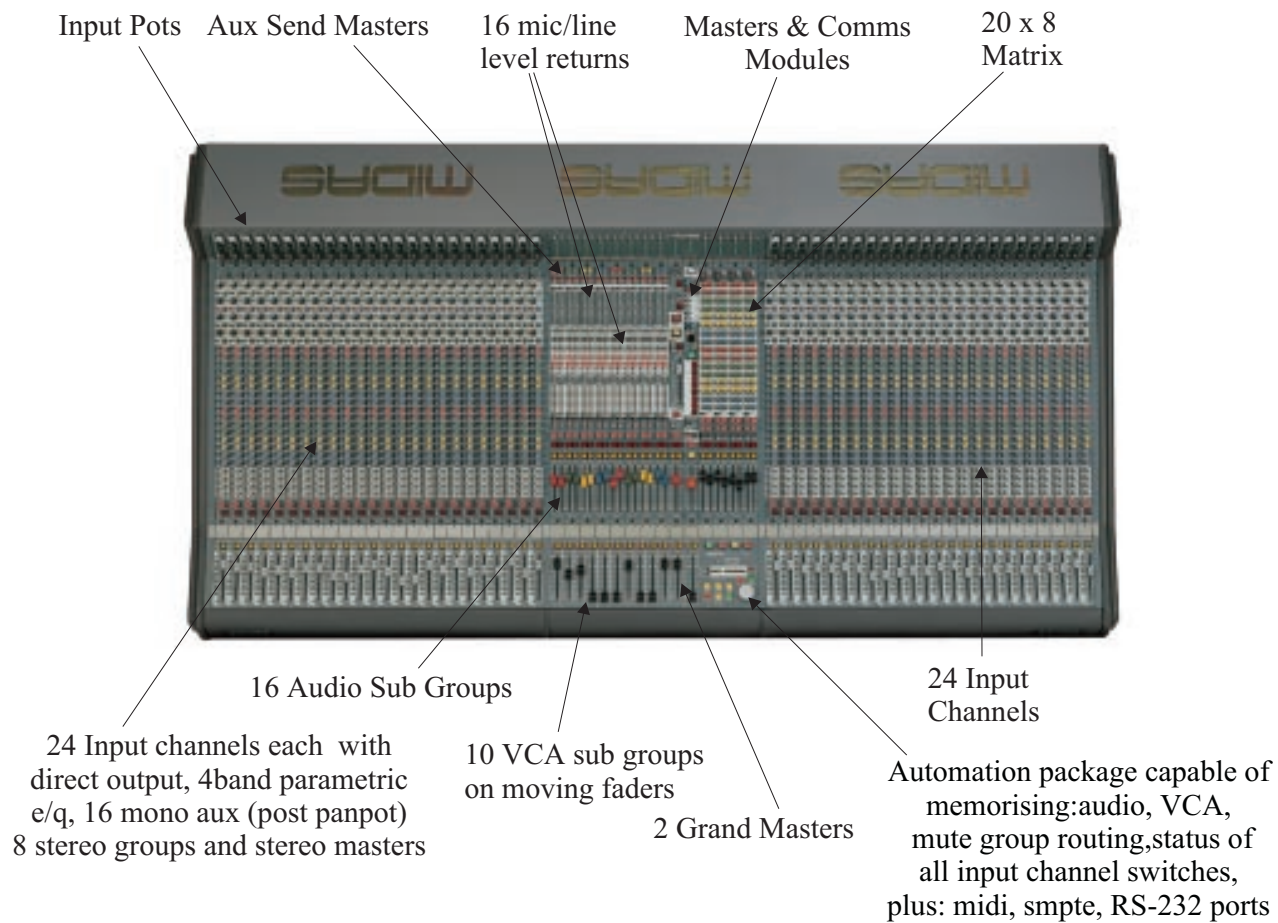

# Midas XL4 Features

## **48 Mic Inputs.**

The XL4 features a new mic amplifier which further improves on the XL3 design giving increased gain range and lower distortion whilst retaining the XL3's constant HF bandwidth topology which assures excellent amplifiers stability, RF rejection and noise performance at all gains.

## **Direct Outputs.**

Every input module is fitted with a direct output as standard with its own level control and front panel switching which selects the source from post fader, pre fader or pre insert and equaliser.

## **16 audio sub groups.**

The 16 main audio groups can be assigned to any of the 8 automute groups and to VCA control from any combination of the 2 motorised grand master faders. A safe switch is again included for each group. The input for the groups is normally derived from the 16 group busses but for monitor applications the fader change over routes the 16 mono aux busses to the group faders.

## **Line inputs.**

A separate Hi Z line input with its own dedicated gain control is incorporated which is ideal for playback of recorded material. Global change over from mic (record) to line (playback) is easy because it is under automation control.

## **Equaliser.**

The sonic performance of the legendary XL3 equaliser is maintained including the full parametric mid's and traditional Midas bass and treble shelving responses. In addition the treble and bass sections now have an extended frequency range and are switchable to full parametric operation.

## **Inserts.**

Each channel has a half normalised fully balanced insert send and return point which can be switched in or out from the front panel and set as either pre or post equaliser.

## **Input metering.**

These peak reading meters cover a 60dB range in 3dB steps and can be switched globally to monitor pre fader signals or pre insert and equaliser signals.

## **Audio busses.**

Each channel can be routed to any combination of 42 audio busses comprising of 16 mono aux'es, 8 stereo aux'es, 16 stereo groups and 2 stereo masters. All this is switchable on the module front panel but also via the automation control.

## **VCA and mute busses.**

Each channel can be controlled by any combination of the 10 motorised VCA master faders and 8 mute masters. Assignment of these busses is again switchable on the module front panel or by the automation control. A safe switch disconnects the channel from all mute groups and an isolate switch removes the channel from all VCA control.

### **Group aux inputs.**

An additional 16 inputs with treble and bass equalisation can be routed directly to the groups or via a pan to the masters mix and can be further controlled by assignment to any of the 10 VCA masters.

### **Master.**

The stereo master module provides the main left and right console outputs plus 4 more record outputs and a mono output. A solo to master facility is incorporated on the left, right and mono outputs to aid the engineer at sound checks.

### **Matrix.**

As standard the 8 matrix outputs derive their signals from the 16 audio groups, left and right masters creating a 18 X 8 matrix. The module also houses the stereo aux masters which have their own outputs at all times but which can be routed directly into the matrix giving an additional 48 X 8 matrix sourcing direct from the input channels.

### **Output meters.**

28 peak reading meters (each covering a 60dB range in 3dB steps) are used to monitor all the main outputs i.e. 16 groups, 8 matrix, 2 masters and 2 local outputs. They and can be switched globally to monitor pre fader or post fader signals and can also be used to monitor the 24 aux outputs.

### **Automutes.**

The 8 automute masters can be assigned to any input or audio group and act on pre fader and post fader signals. Apart from assignment the operation of these mutes is entirely independent of the automation system.

### **10 input VCA faders.**

10 motorised VCA master faders control the channel and aux inputs whilst a further 2 VCA grand master faders control the audio groups. Each VCA master has a solo switch which gives the engineer an opportunity to monitor the signals within the VCA subgroup. Also incorporated is a VCA mute which act on post fader signals only and effectively adds a further 12 automute scenes to the existing dedicated automutes.

### **Automation.**

The automation system can store and recall up to 2000 scenes. All channel routing and major functions are automated as well as all major output mutes. The 12 motorised VCA master faders give dynamic control of signal levels within the console and all automation information can be exported or imported in a variety of different mediums for storage or console and system linking.



## XL4 Specification Overview and Statistics.

1. The XL4 is a 45 buss console with an additional 18 X 8 output matrix. The busses are as follows:-

16 mono aux	=	16
16 audio sub groups	=	16
4 stereo aux	=	8
1 stereo master	=	2
1 stereo AFL	=	2
1 mono PFL	=	1
TOTAL	=	45

2. The XL4 has 8 automute sub groups, 10 input channel VCA sub groups which include VCA sub group muting and 2 grand master VCA sub groups with VCA sub group muting.

3. The XL4 has 48 input channels with separate line and mic inputs plus an additional 16 aux line returns.

4. The XL4 has a total XLR input count of 171 as follows:-

- 48 channel line inputs
- 48 channel mic inputs
- 24 aux bus inject inputs
- 16 audio group bus inject inputs
- 16 aux line returns inputs
- 8 matrix bus inject inputs
- 3 solo bus inject inputs
- 2 master bus inject inputs
- 1 comms mic input ( headset )
- 1 comms input ( and output )
- 1 talk mic input
- 1 talk bus inject input
- 1 midi input

5. The XL4 has a total XLR output count of 111 as follows:-

- 48 input channel direct outputs
- 24 aux outputs
- 16 audio group outputs
- 8 matrix outputs
- 4 record outputs
- 3 master outputs
- 3 solo outputs
- 2 local outputs
- 2 midi outputs
- 1 talk output

6. The XL4 has a total bantam jack field count of 158 as follows:-

- 56input channel insert sends ( 8 spare for stereo module up grades )
- 56input channel insert returns ( 8 spare for stereo module up grades )
- 16audio group insert sends
- 16audio group insert returns
- 8matrix insert sends
- 8 matrix returns
- 8parallel links ( 2 sets of 4 )
- 3 master insert sends
- 3master insert returns

7. The XL4 has 12 motorised moving faders for the VCA masters.

8. The XL4 has a total of 2539 automated switch functions as follows:-

- 960input channel aux send on off switches
- 480input channel VCA sub group assign switches
- 384input channel audio sub group assign switches
- 384input channel mute sub group assign switches
- 48input channel EQ on off switches
- 48input channel stereo master on off switches
- 48input channel phase switches
- 48input channel insert on off switches
- 48input channel mic line switches
- 48input channel mute switches
- 16audio sub group mute switches
- 16aux line return mute switches
- 8matrix mute switches
- 3master mute switches

9. The XL4 has a total of 77 peak program meters with 20 LED segments each and monitoring 282 signal points ,

## XL4 Technical Specification.

Input Impedance	Mic	2K Balanced
	Line	20K Balanced
Input Gain ( all faders at 0dB )	Mic	Continuously variable from + 15dB to + 70dB
	Mic + Pad	Continuously variable from - 5dB to + 50dB
	Channel Line Input	Continuously variable from - 20dB to + 20dB
	All other Line Inputs	0dB
Maximum Input Level	Mic	+ 6dBu
	Mic + Pad	+ 26dBu
	Channel Line inputs	+ 26dBu
	All other Line Inputs	+ 21dBu
CMR at 1KHz	Mic ( gain + 60dB )	> 70dB
	Mic + Pad ( gain + 40dB )	> 50dB
	Line	> 60dB
Frequency Response ( 20 to 20KHz )	Mic to Mix ( gain + 60dB )	+ 0dB to - 1dB
	Line to Mix	+ 0dB to - 1dB
Noise ( 20 to 20KHz )	Mic EIN ref. 150 Ohms ( gain + 60dB )	- 129dBu
	Line EIN ref. 150 Ohms ( gain + 10dB )	- 100dBu
System Noise ( 20 to 20KHz )	Summing Noise ( 12 channels routed with faders down )	- 86dB
	Line to Mix Noise ( 12 channels routed at 0dB, pan centre )	- 81dB
Summing Noise	( 48 channels routed with faders down )	- 80dB
	Line to Mix Noise ( 48 channels routed at 0dB, pan centre )	- 75dB

Distortion at 1KHz	Mic to Mix ( + 60dB gain, 0dBu output )	< 0.03%
	Line to Mix ( 0dBu )	< 0.03%
Crosstalk at 1 KHz	Channel to Channel	< - 100dB
	Mix to Mix	< - 90dB
	Channel to Mix	< - 90dB
	Maximum Fader attenuation	> 90dB
Output Impedance	All Line Outputs	50 Ohms Balanced Source to drive > 600 Ohms
	Headphones	To drive > 8 Ohms Unbalanced
	Comms ( Bi - directional )	600 Ohms Nominal Unbalanced
Maximum Output Level	All Line Outputs	+ 21dBu
	Headphones	+ 21dBu ( 8W into 8 Ohms )
	Comms ( Bi - directional )	- 10dBu
Nominal Signal Level	Mic	- 70dBu to + 5dBu
	Channel Line Inputs	- 20dBu to + 5dBu
	All other Line Inputs and outputs	0dBu
	Headphones	+ 10dBu
	Comms	- 20dBu
	Comms and Talk Mic	- 50dBu to - 20dBu ( auto gain )
Headroom at all stages	Comms, Talk and Headphone	> 10dB
	All other signals	> 20dB
Metering	Type	20 led peak reading
	Range	- 36dBu to + 21dBu
	Colour Green	Up to + 9dBu Normal signal
	Colour Yellow	+ 12dBu to + 15dBu High signal
	Colour Red	Over + 18dBu Signal Too High
	Quantity	77 ( Monitoring all main Inputs and outputs )

## Equaliser

Low pass slope	12dB / Oct.
Low pass frequency	Continuously variable -3dB point from 1K to 40K
Hi pass slope	12dB / Oct.
Hi pass frequency	Continuously variable 3dB point from 10Hz to 400Hz
Treble Gain	Continuously variable + 15 dB to - 15 dB Centre detent = 0dB
Treble Shelving Freq.	Continuously variable - 3dB point from 1K to 20K
Treble Bell Freq.	Continuously variable centre from 1K to 20K
Treble Bell Bandwidth	Continuously variable 0.1 Oct. to 2 Oct. Centre detent = 0.5 Oct.
Hi Mid Gain	Continuously variable + 15 dB to - 15 dB Centre detent = 0dB
Hi Mid Freq.	Continuously variable centre from 400Hz to 8K
Hi Mid Bandwidth	Continuously variable 0.1 Oct. to 2 Oct. Centre detent = 0.5 Oct.
Lo Mid Gain	Continuously variable + 15 dB to - 15 dB Centre detent = 0dB
Lo Mid Freq.	Continuously variable centre from 100Hz to 2K
Lo Mid Bandwidth	Continuously variable 0.1 Oct. to 2 Oct. Centre detent = 0.5 Oct.
Bass Gain	Continuously variable + 15 dB to - 15 dB Centre detent = 0dB
	Bass Shelving Freq. Continuously variable 3dB point from 20Hz to 400Hz
Bass Bell Freq.	Continuously variable centre from 20Hz to 400Hz
Bass Bell Bandwidth	Continuously variable 0.1 Oct. to 2 Oct. Centre detent = 0.5 Oct.



# XL4 INPUT BLOCK DIAGRAM

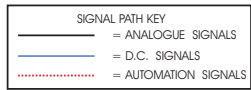
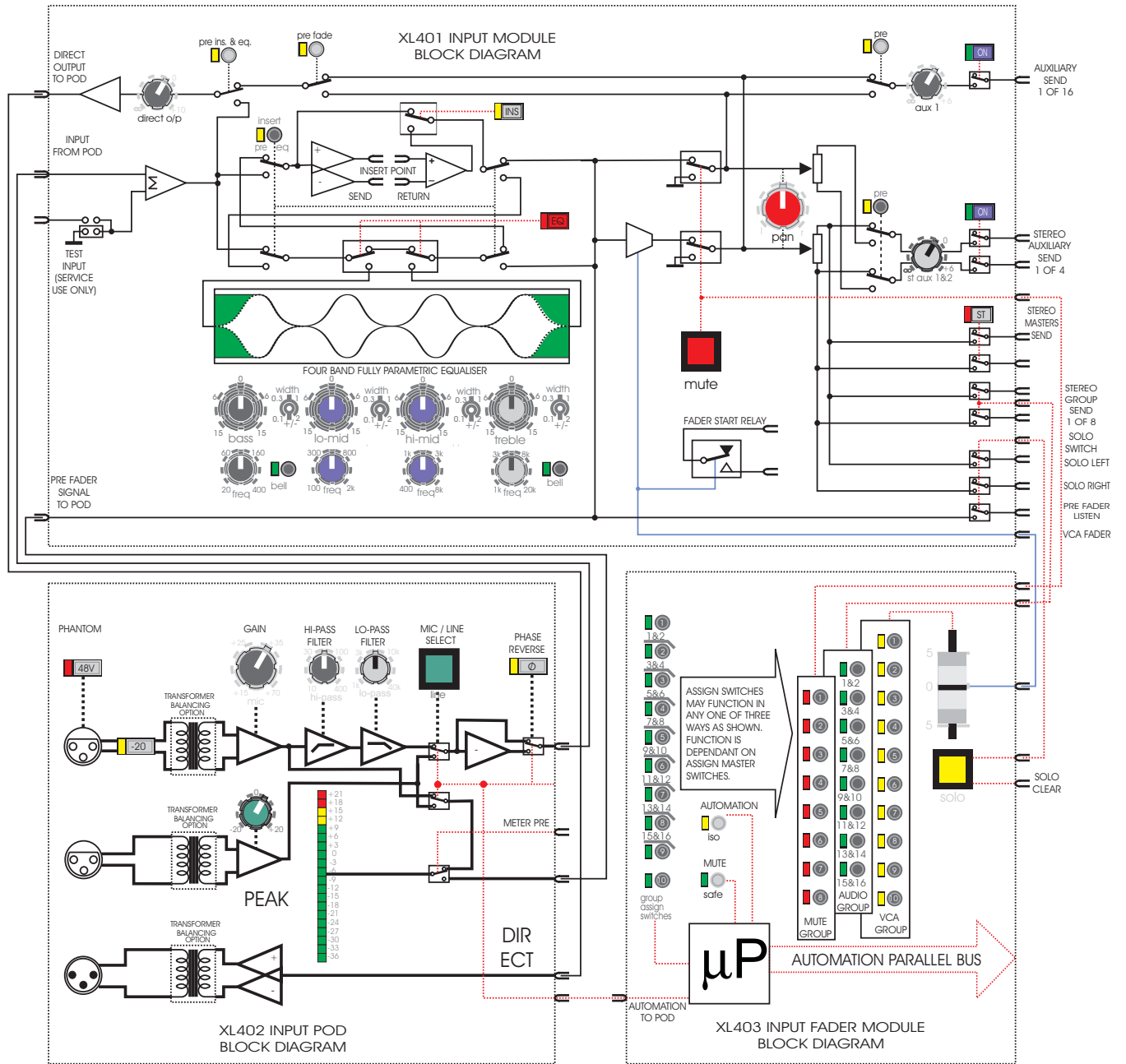

# XL4 MATRIX MODULE BLOCK DIAGRAM

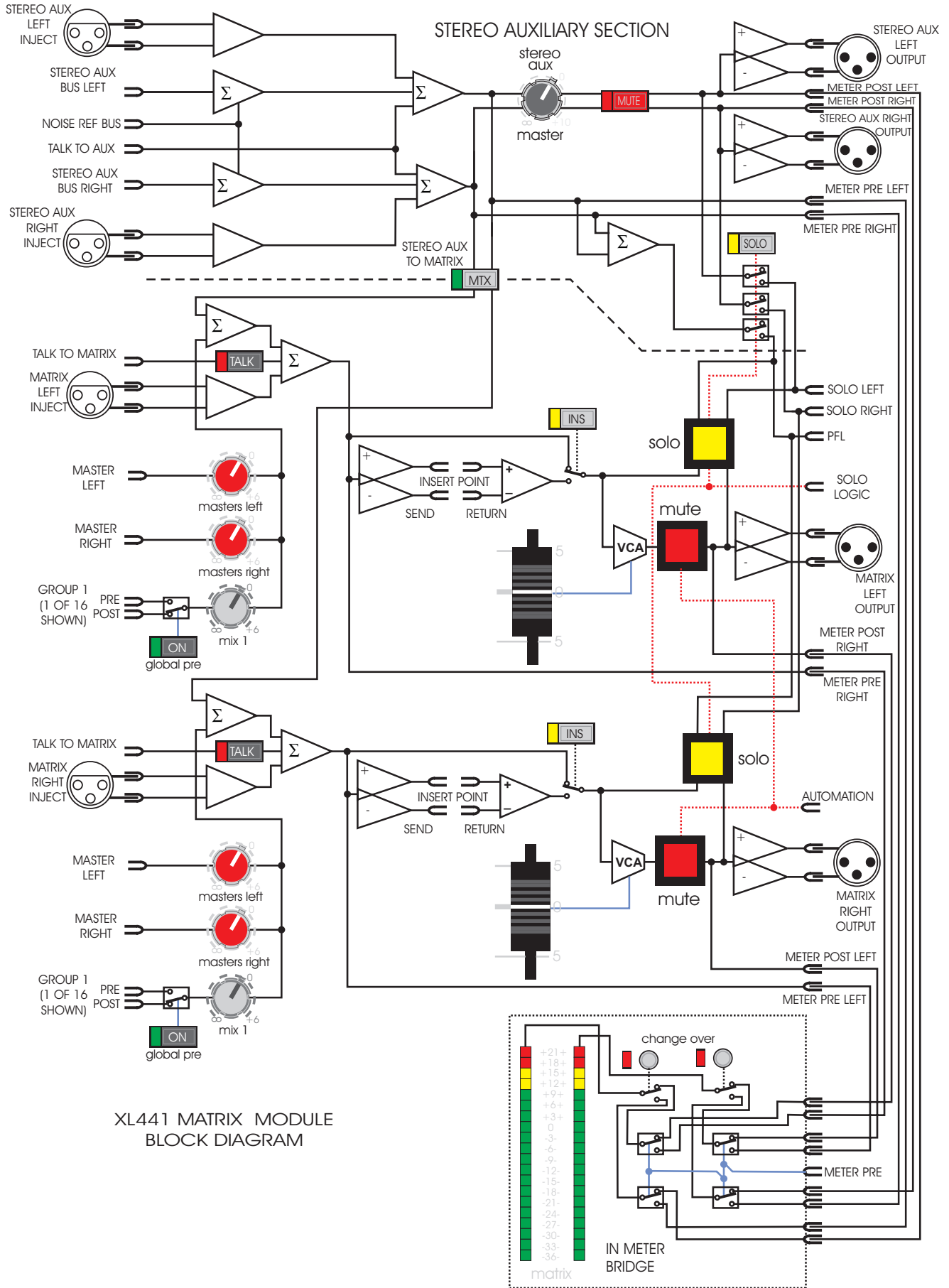

XL41 MATRIX MODULE  
BLOCK DIAGRAM







# MIDAS XL4 REAR PANEL

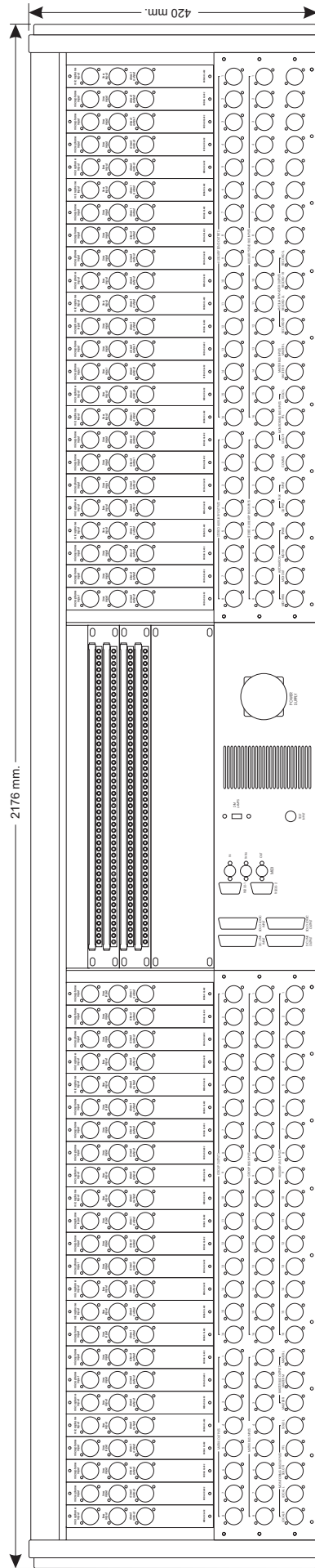

## XL4 STANDARD PATCH PANEL

Depth 1120mm  
 Nett Weight 229kg / 505lb

Other Dimensions:

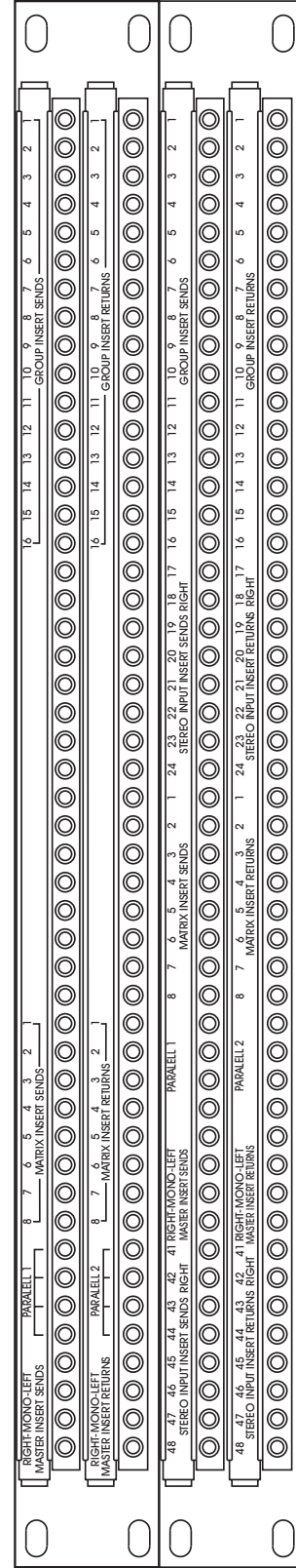

Please Note: XL4s are wired to take stereo channels in positions 17-24 and 41-48 as standard.

## Typical Remote Patch Bay Option Panels

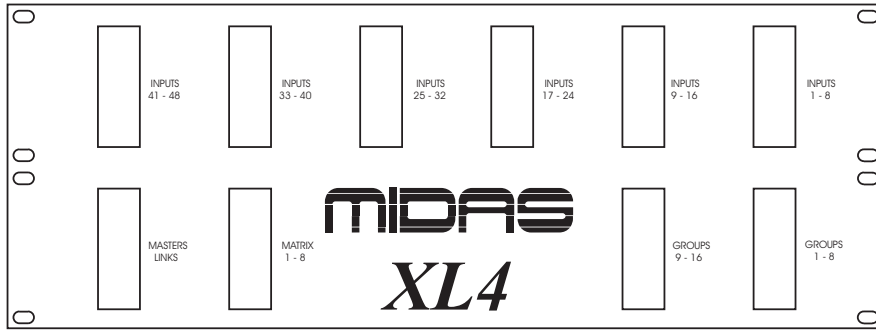

Edac Mono Inputs Panel

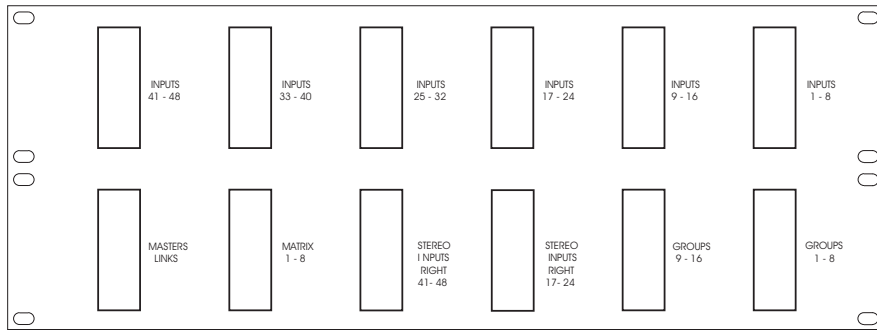

Edac Mono & Stereo Inputs Panel

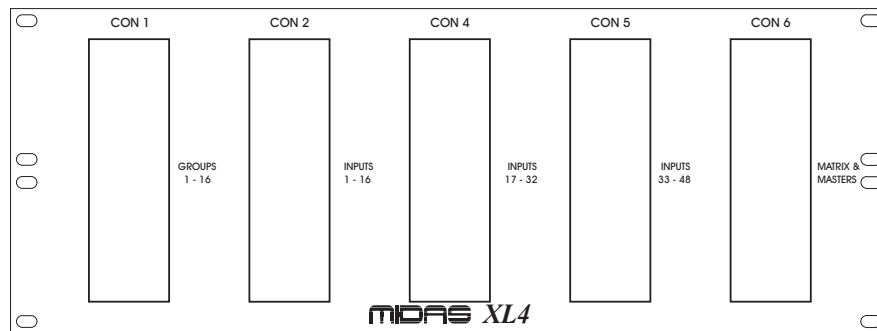

Harting Mono Inputs Panel

## Typical All Connections Multi-Pin

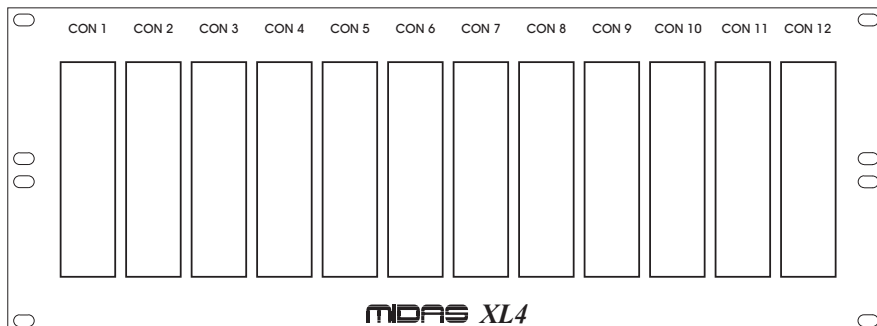

Using Siemens remote all connections

# REAR PANEL DETAIL

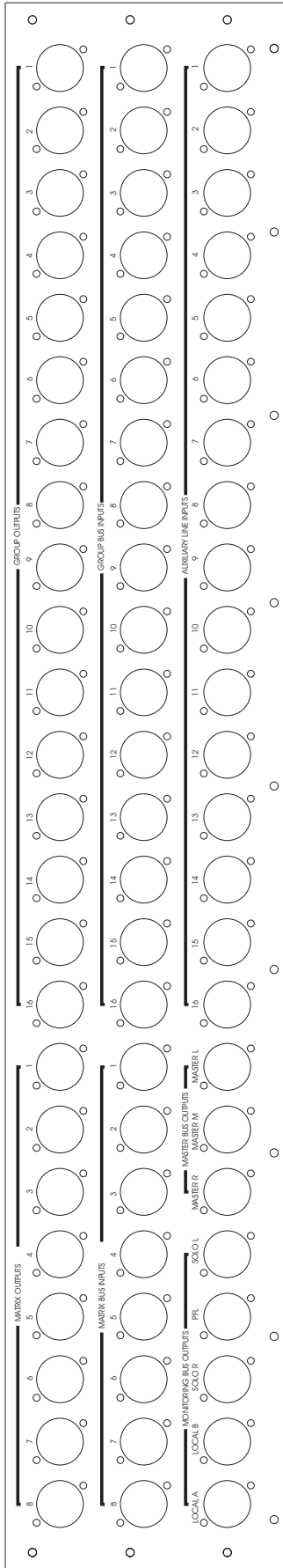

Left Rear View

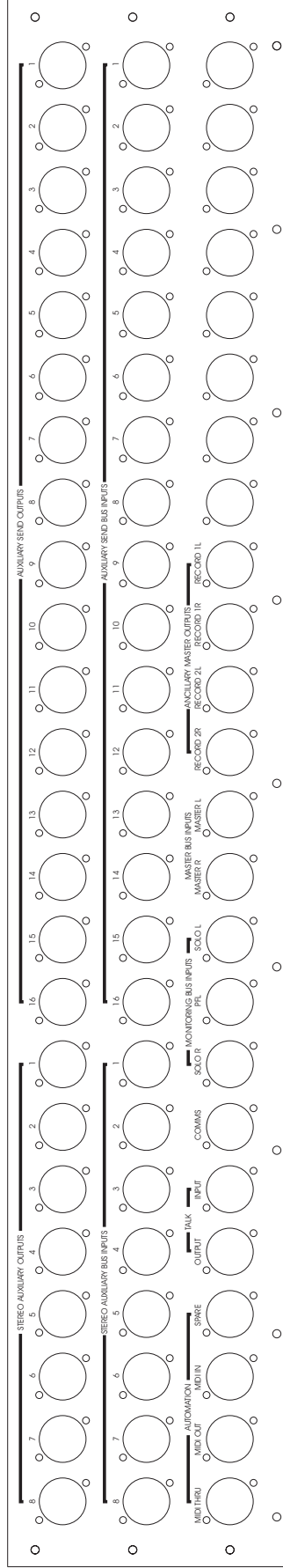

Right Rear View

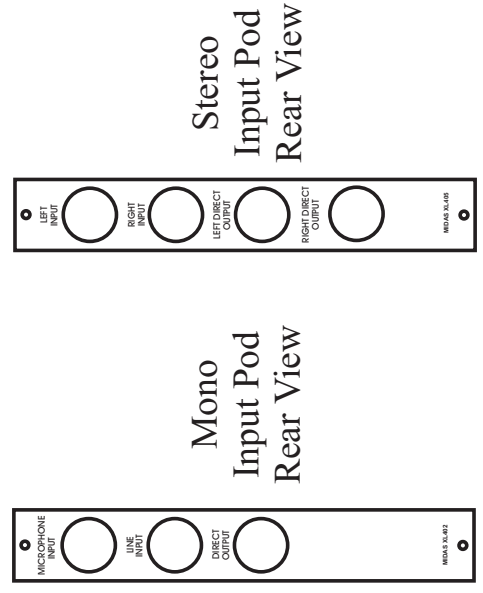
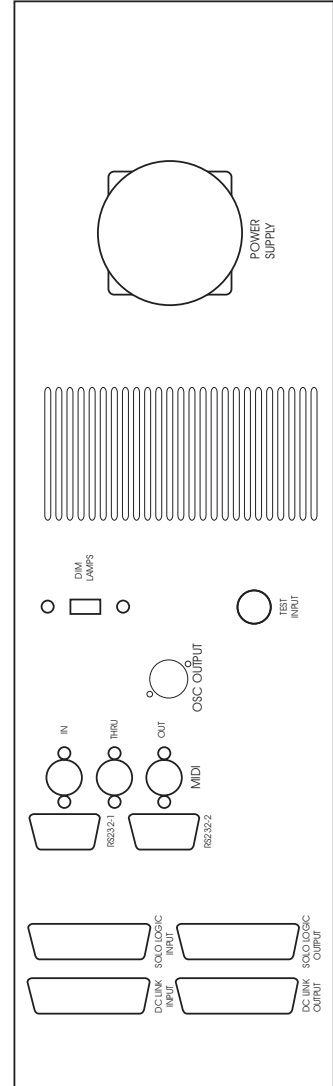



# MIDAS XL402 Input Pod

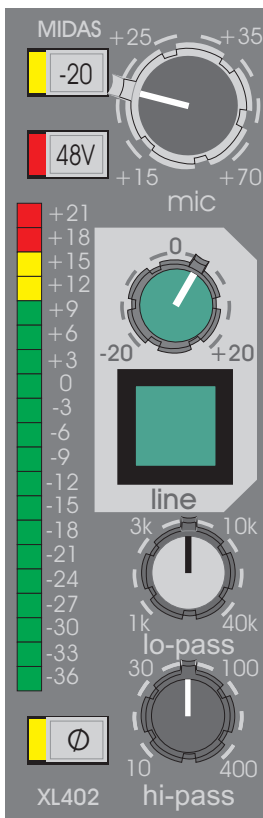

FUNCTION: To control microphone and line input levels with phantom and phase reverse facility plus incorporating high and low pass filters.

The PAD switch gives 20dB of attenuation to the mic signal and will allow the connection of high output microphones or line level signals. If the mic amp is transformer coupled ( option ) the pad greatly reduces the risk of saturation at very low frequencies.

The 48V switch connects 48 volt phantom power to the mic input suitable for a condenser microphone or DI box.

The METER monitors the peak signal level of the input channel pre fader. When the GLOBAL METER CHANGE OVER switch on the COMMS module is activated the meter monitors the mic amp or line amp output (which ever is in use ).

The PHASE switch activates a 180 degrees phase change on both the mic and line inputs. This switch is under automation control.

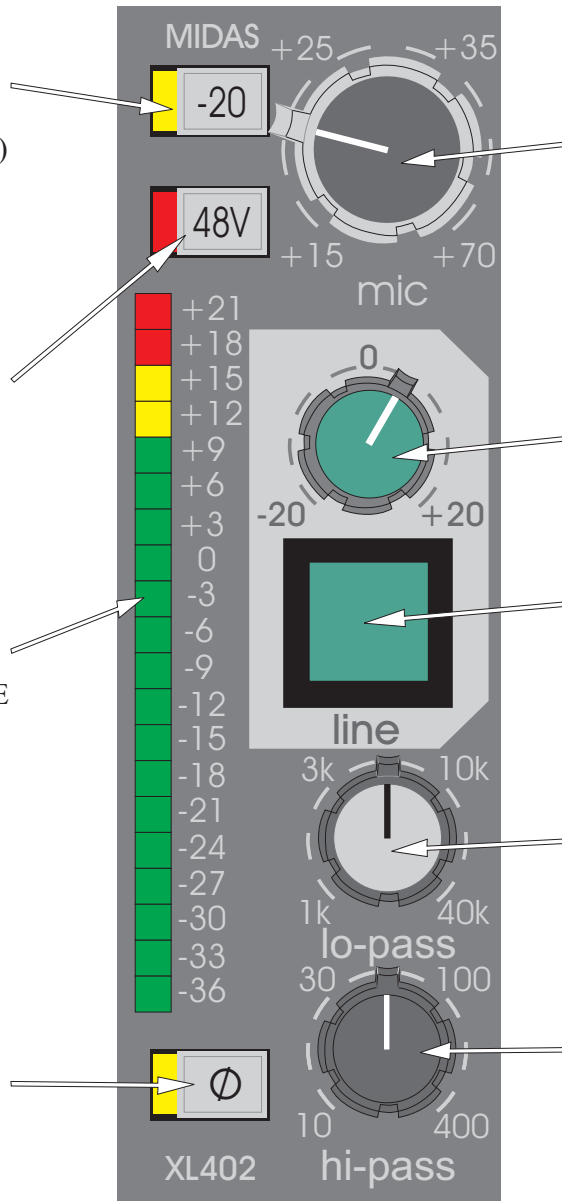

The MIC control gives continuous adjustment of the mic amp gain from + 15dB to + 70dB.

The LINE control gives continuous adjustment of the line amp gain from - 20dB to + 20dB.

The LINE switch connects the line input to the signal path and disconnects the mic amplifier. This switch is under automation control.

The LO PASS filter control acts on the mic input only and is continuously adjustable from 1K to 40K. When the filter is set to 40K there is no loss at 20K.

The HI PASS filter control acts on the mic input only and is continuously adjustable from 10Hz to 400Hz. When the filter is set to 10Hz there is no loss at 20Hz.





# MIDAS XL401 Input Module

The PRE INS & EQ switch re configures the direct output to derive signal from the input channel pre insert and

The PRE FADE switch re configures the direct output to derive signal from the input channel pre fader.

The treble WIDTH ( dual concentric bottom ) control gives continuous adjustment of bandwidth from 0.1 to 2 octaves with a 0.5 octave centre detent. This only operates when the BELL switch is activated.

The treble BELL switch converts the treble equaliser from traditional MIDAS shelving response to full parametric operation.

The HI MID ( dual concentric top ) control gives continuous adjustment of boost and cut from + 15dB to - 15dB with a 0dB centre detent.

The EQ switch connects the equaliser in the input channel signal path and is under automation control.

The LO MID ( dual concentric top ) control gives continuous cut from + 15dB to - 15dB with a 0dB centre detent.

The INSERT PRE EQ arranges the input channel signal to pass through the insert point before the equaliser when activated and after the equaliser when not activated.

The BASS ( dual concentric top ) control gives continuous adjustment of boost and cut from + 15dB to - 15dB with a 0dB centre detent.

The bass BELL switch converts the bass equaliser from traditional MIDAS shelving response to full parametric operation.

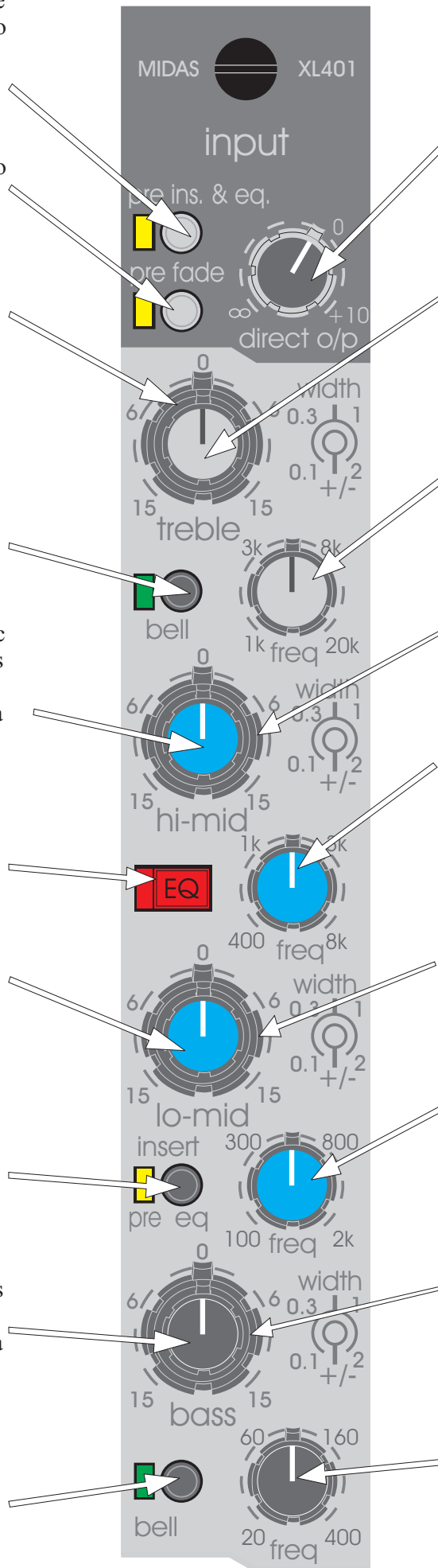

The DIRECT output control gives continuous adjustment of the direct output level from + 10dB to off. The output is derived from the input channel post fader signal.

The TREBLE ( dual concentric top ) control gives continuous adjustment of boost and cut from + 15dB to - 15dB with a 0dB centre detent.

The treble FREQ control gives continuous adjustment of the frequency range that the treble equaliser acts on from 1K to 20K.

The hi mid WIDTH ( dual concentric bottom ) control gives continuous adjustment of bandwidth from 0.1 to 2 octaves

The hi mid FREQ control gives continuous adjustment of the frequency range that the hi mid equaliser acts on from 400Hz to 8K.

The lo mid WIDTH ( dual concentric bottom ) control gives continuous adjustment of bandwidth from 0.1 to 2 octaves with a 0.5 octave centre detent.

The lo mid FREQ control gives continuous adjustment of the frequency range that the lo mid equaliser acts on from 100Hz to 2K.

The bass WIDTH ( dual concentric bottom ) control gives continuous adjustment of bandwidth from 0.1 to 2 octaves with a 0.5 octave centre detent. This only operates when the BELL switch is activated.

The bass FREQ control gives continuous adjustment of the frequency range that the bass equaliser acts on from 20Hz to 400Hz.

The mono aux ON switches (1 to 16) connect signals from the input channel to the mono aux busses and are under automation control.

The mono aux PRE switches change the signal sent to the mono aux busses from post fader to pre fader.

The mono AUX controls ( 1 to 16 ) give continuous adjustment of the level sent from the input channel to the aux busses. The level adjustment is from + 6dB to off.

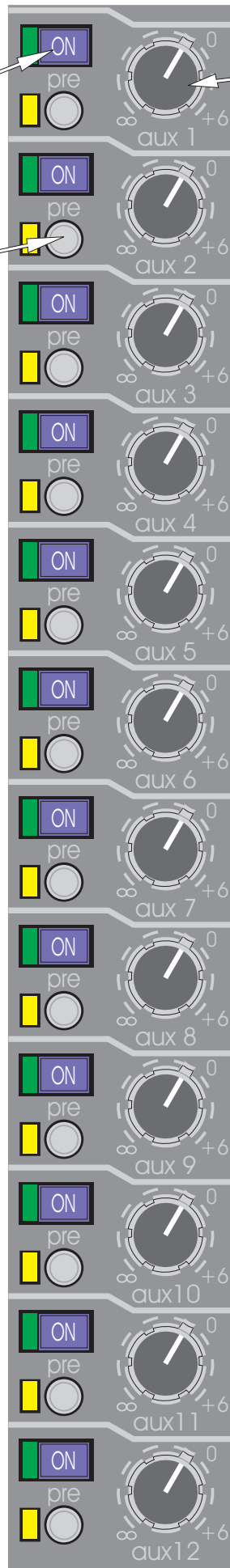

1 - 16

The stereo aux ON switches (1-4) connect signals from the input channel to the stereo aux busses and are under automation control.

The stereo aux PRE switches (1-4) change the signal sent to the stereo aux busses from post fader to pre fader whilst retaining the post pan stereo image.

The INS switch connects the input insert return signal to the input channel before or after the equaliser (see insert pre eq switch on page 4) and is under automation control.

The ST switch connects the input channel post fader signal to the stereo master buss via the pan control and is under automation control.

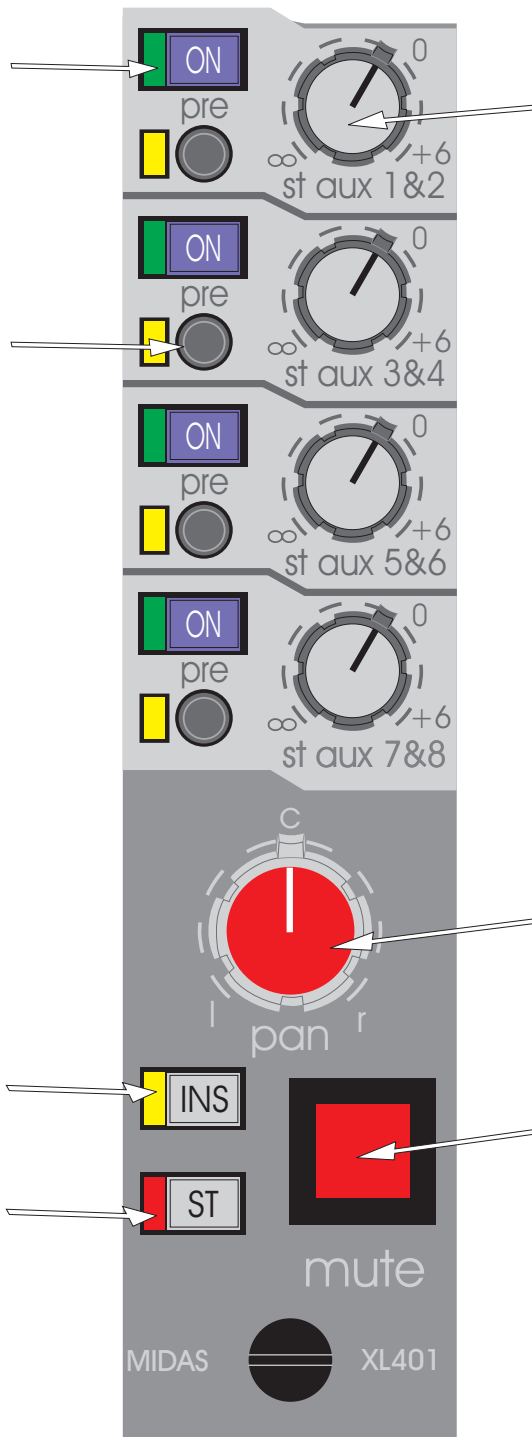

The ST AUX controls (1 to 8) give continuous adjustment of the level sent from the input channel (post pan) to the stereo aux busses. The level adjustment is from + 6dB to off.

ST AUX OPTION:- Consoles can be ordered with dual concentric controls to give independent adjustment of the levels sent from the input channel (pre pan) to the stereo busses. The top control gives adjustment of left signals from +6dB to off while the bottom control adjusts the right signal levels.

The PAN control places the input channel within a stereo mix and has a constant power law i.e. - 3dB at the centre position.

The MUTE switch mutes the input channel at all points except the insert send and pre insert / eq direct output. This switch is under automation and auto mute group control.

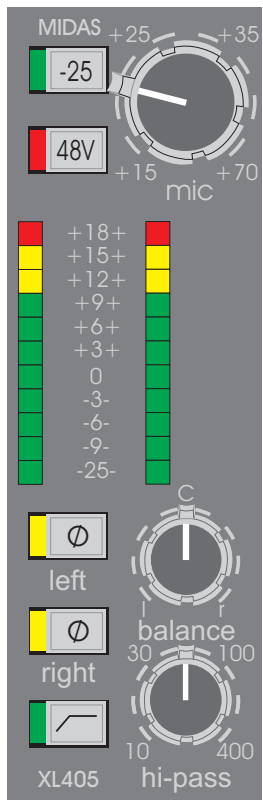

# MIDAS XL405 Stereo Input Pod

The PAD switch gives 25dB of attenuation to the mic signals and will allow the connection of high output microphones or line signals. If the mic amps are transformer coupled (option) the pad greatly reduces the risk of saturation at very low frequencies.

The 48V switch connects 48 volt phantom power to both mic inputs as required for condenser microphones etc.

The METERS monitors the peak signal level of the left and right input channels pre fader. When the GLOBAL METER CHANGE OVER switch on the COMMS module is activated the meters monitor the left and right mic/line amp outputs.

The left PHASE switch activates a 180 degrees phase change on the left mic/line input.

The right PHASE switch activates a 180 degrees phase change on the right mic/line input.

The HI PASS switch connects the high pass filter into the left and right signal path.

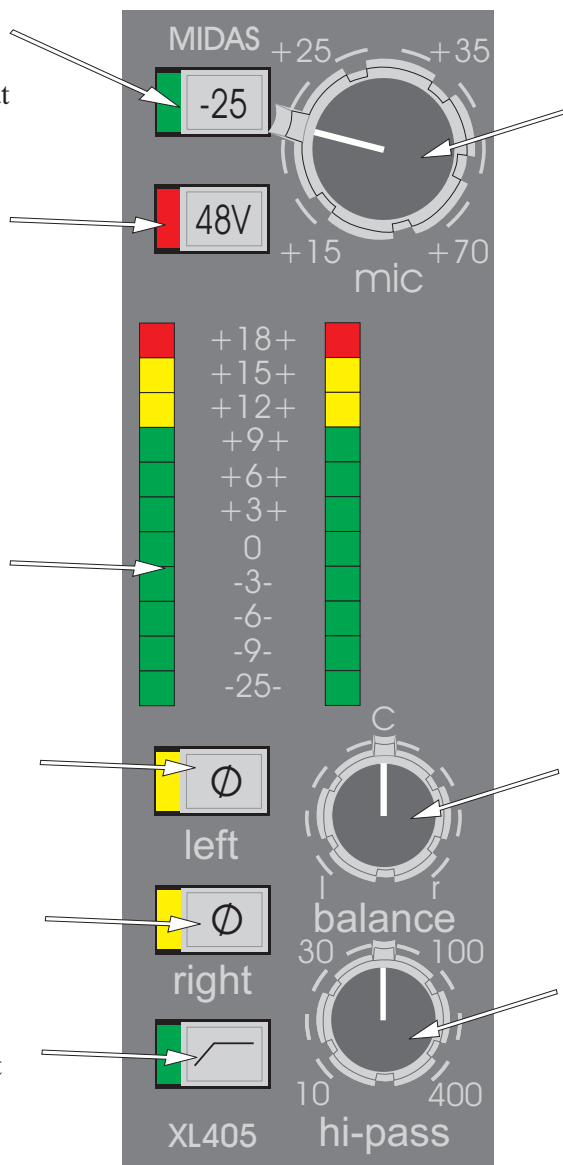

The MIC control gives continuous adjustment of left and right mic amp gains from +15dB to +70dB.

The BALANCE control gives continuous and reciprocal adjustment of the stereo left and right signal levels by +10dB to -10dB. This allows fine adjustment of the left and right signal levels and imaging.

The HI PASS filter control is continuously adjustable from 10Hz to 400Hz.

The stereo input pod provides a left and right DIRECT OUTPUT which can be internally linked as pre or post insert/eq.



# MIDAS XL404 Stereo Input Module

MIDAS XL404

stereo input

The TREBLE control gives continuous adjustment of left and right shelving filters boost and cut from +15dB to -15dB with a 0dB centre detent.

The HI MID control gives continuous adjustment of left and right boost and cut from +15dB to -15dB with a 0dB centre detent.

The LO MID control gives continuous adjustment of left and right boost and cut from +15dB to -15dB with a 0dB centre detent.

The EQ switch connects the left and right equalisers in the input channel signal paths and is under automation control.

The BASS control gives continuous adjustment of the left and right shelving filters boost and cut from +15dB to -15dB with a 0dB centre detent.

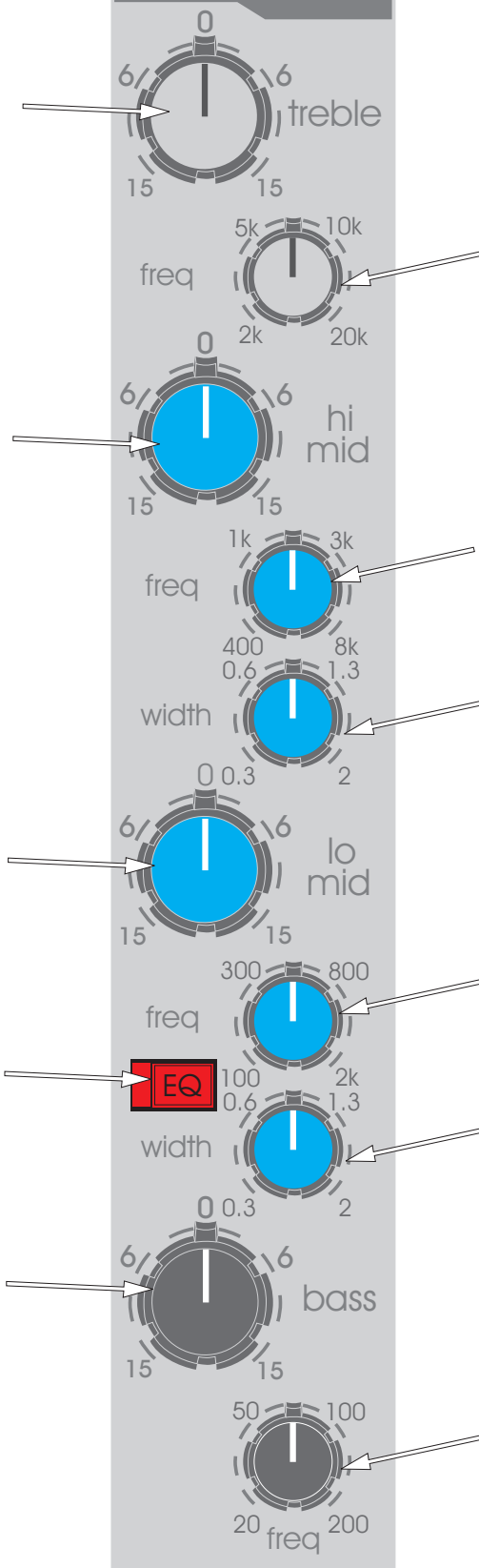

The treble FREQ control gives continuous adjustment of the frequency range that the treble equalisers act on from 2K to 20K.

The hi mid FREQ control gives continuous adjustment of the frequency range that the hi mid equalisers act on from 400Hz to 8K.

The hi mid WIDTH control gives continuous adjustment of the filter bandwidths from 0.3 to 2 octaves with 1 octave being the centre position.

The lo mid FREQ control gives continuous adjustment of the frequency range that the lo mid equalisers act on from 100Hz to 2K.

The lo mid WIDTH control gives continuous adjustment of the filter bandwidths from 0.3 to 2 octaves with 1 octave being the centre position.

The bass FREQ control gives continuous adjustment of the frequency range that the bass equalisers act on from 20Hz to 200Hz.



The mono aux ON switches connect signals from the input channel to the mono aux busses and are under automation control.

The mono aux PRE switches change the signal sent to the mono aux busses from post fader to pre fader.

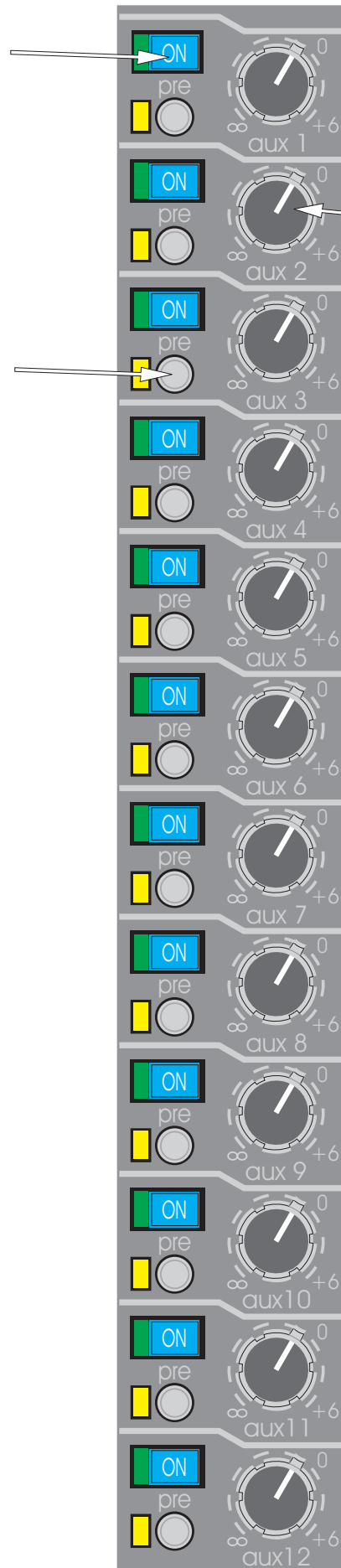

The mono AUX controls (1 to 16) give continuous adjustment of the level sent from the input channel to the aux busses. The signal is a mono sum of the left and right signals and the level adjustment is from +6dB to off.

The stereo aux ON switches connect signals from the input channel to the stereo aux busses and are under automation control.

The stereo aux PRE switches change the signal sent to the stereo aux busses from post fader to pre fader whilst retaining the post pan stereo image.

The INS switch connects the left and right input insert return signals to the input channel and is under automation control.

The ST switch connects the input channel post fader signals to the stereo master buss via the pan controls and is under automation control.

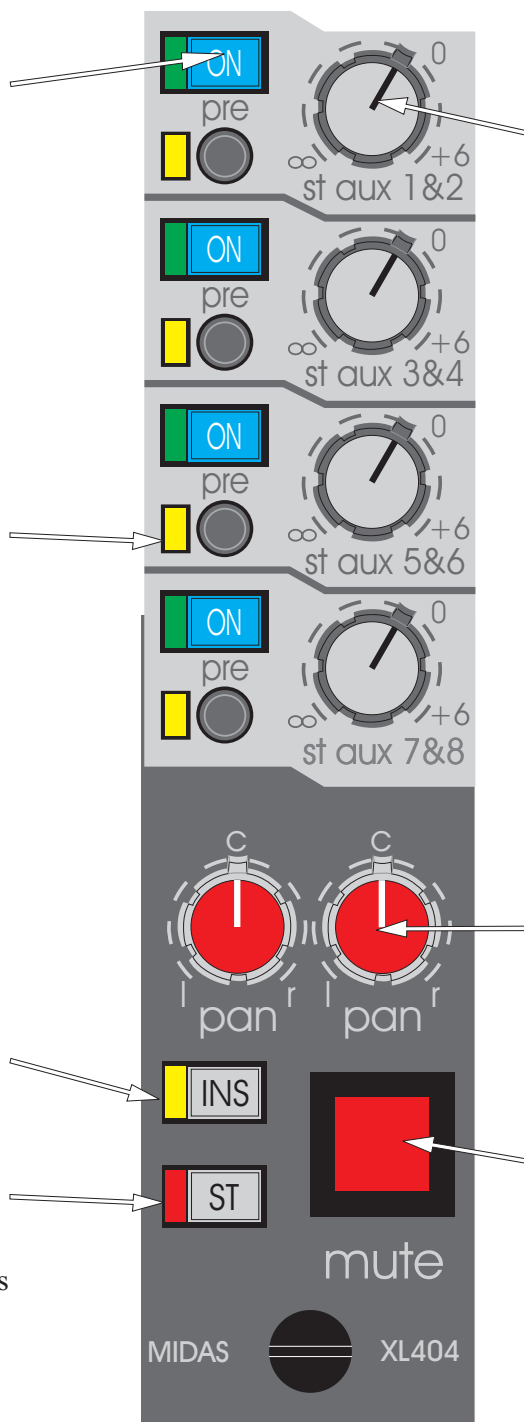

The ST AUX controls (1 to 8) give continuous adjustment of the level sent from the input channel (post pan) to the stereo aux busses. The level adjustment is from +6dB to off.

The left and right PAN controls are used to place the input channel signals within a stereo mix. As well as image placement, the controls can also adjust the image width from stereo through mono to reverse stereo (left and right crossed over). The controls have a constant power law i.e. -3dB at the centre position.

The MUTE switch mutes the input channel at all points except the insert send and pre insert/eq direct output. This switch is under automation and auto mute group control.

# MIDAS XL403

## Input VCA Fader

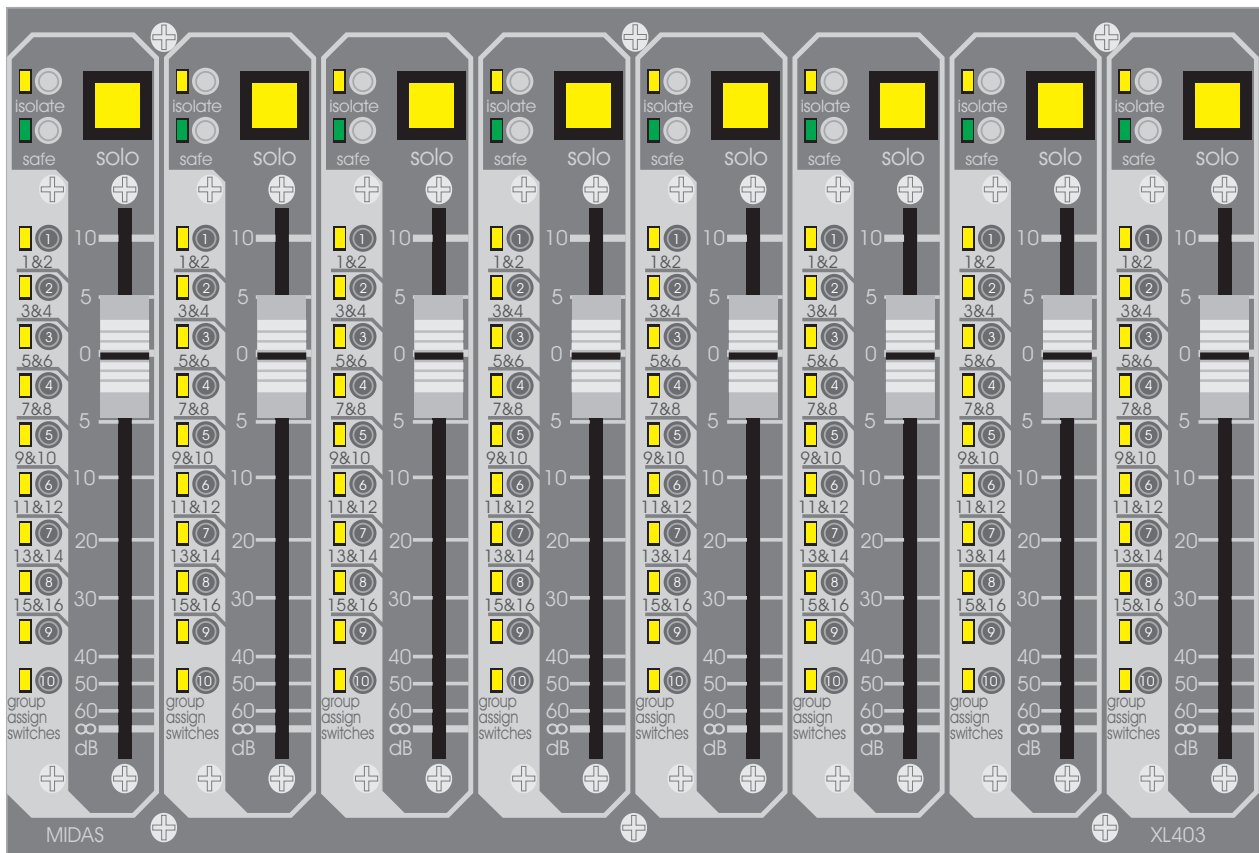

FUNCTION: Fader control of 48 input levels to stereo bus, audio sub groups and VCA sub groups with solo and mute group assign.

The ISOLATE switch disconnects the input channel from automation scene recall. Scene storage is still active.

The SAFE switch disconnects the input channel mute from the 8 auto mute busses.

The GROUP ASSIGN SWITCHES 1 to 10 are under automation control and perform 3 major functions:-

- i. They are used to assign the input channel post fader signal to the 16 AUDIO groups via the pan control.
- ii. They are used to assign the input channel to the 10 VCA sub groups.
- iii. They are used to assign the input channel to the 8 auto MUTE groups.

The function of these switches is globally selected by pressing the large AUDIO, VCA or MUTE switches on the AUTOMATION CENTRAL CONTROL panel. A fourth large switch LOCK is used to disable all the input channel group assign switches throughout the console so as to avoid accidental operation. It is still possible to view the switch status of all three group types when in this mode.

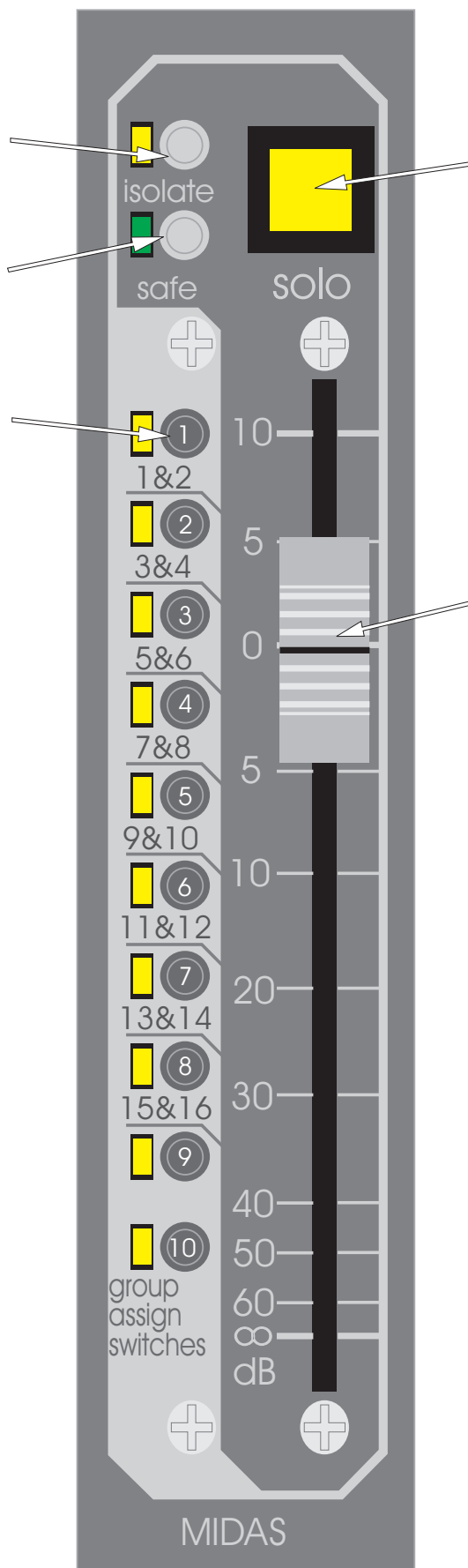

The SOLO switch sends the input channel signal to the PFL mono and AFL stereo busses. If the switch is pressed for a short time it will latch on or off, but, if it is held on for more than 1 second the latching is disabled and when the switch is released the channel solo will turn off.

The VCA INPUT fader gives continuous adjustment of the input channel level from +10dB to off.

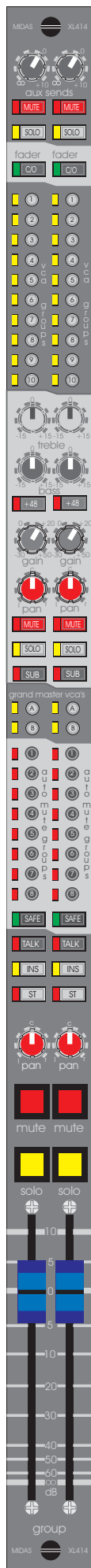

# MIDAS XL414 Group Module

# AUX SENDS

The aux send SOLO switches send mono aux bus signals to the PFL and AFL busses. If a switch is pressed for a short time it will latch on or off, but if it is held on for more than 1 second the latching is disabled and when the switch is released the solo will turn off.

The FADER CHANGE OVER switches swap the mono aux busses with the audio group busses so that the console can be used for monitor applications.

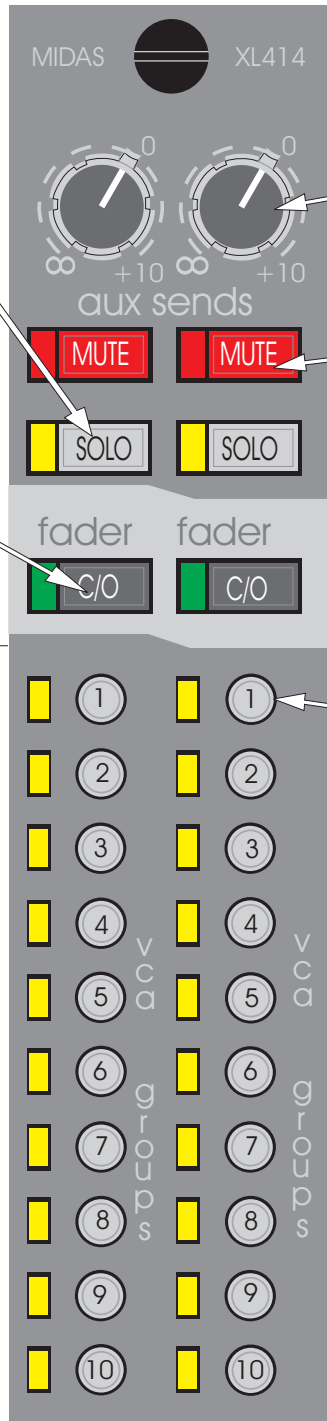

The AUX SEND controls give continuous adjustment of the mono aux bus output levels from +10dB to off.

The aux send MUTE switches mute the aux bus outputs.

The VCA GROUP switches assign the mic/line returns to

# MIC/LINE RETURNS

# MIC/LINE RETURNS

The BASS Controls give continuous adjustment of boost and cut from +15dB to -15dB with a 0dB centre detent. The frequency is fixed at 100Hz.

The 48V switches connect 48 volt phantom power to the mic/line inputs as required for condenser microphones etc.

The mic/line return PAN controls place the return signals within the stereo master mix and have a constant power law i.e. -3dB at the centre position.

The SUB switches disconnect the mic/line returns from the stereo master buss and route the signals to the audio sub groups directly below, without passing through the pan control.

The AUTO MUTE GROUP switches assign the audio sub groups to the 8 auto mute groups.

The SAFE switches disconnect the audio sub group mutes from the auto mute busses.

The TREBLE controls give continuous adjustment of boost and cut from +15dB to -15dB with a 0dB centre detent. The frequency is fixed at 10KHz.

The GAIN controls give continuous adjustment of the mic/line return gains from +50dB to -30dB. The special input circuits maintain full headroom from mic level to line level without the use of a pad.

The mic/line return MUTE switches mute the return signals and are under automation control.

The mic/line return SOLO switches send the return signals to the mono PFL and stereo AFL busses. If a switch is pressed for a short time it will latch on or off, but if it is held on for more than 1 second the latching is disabled and when the switch is released the solo will turn off.

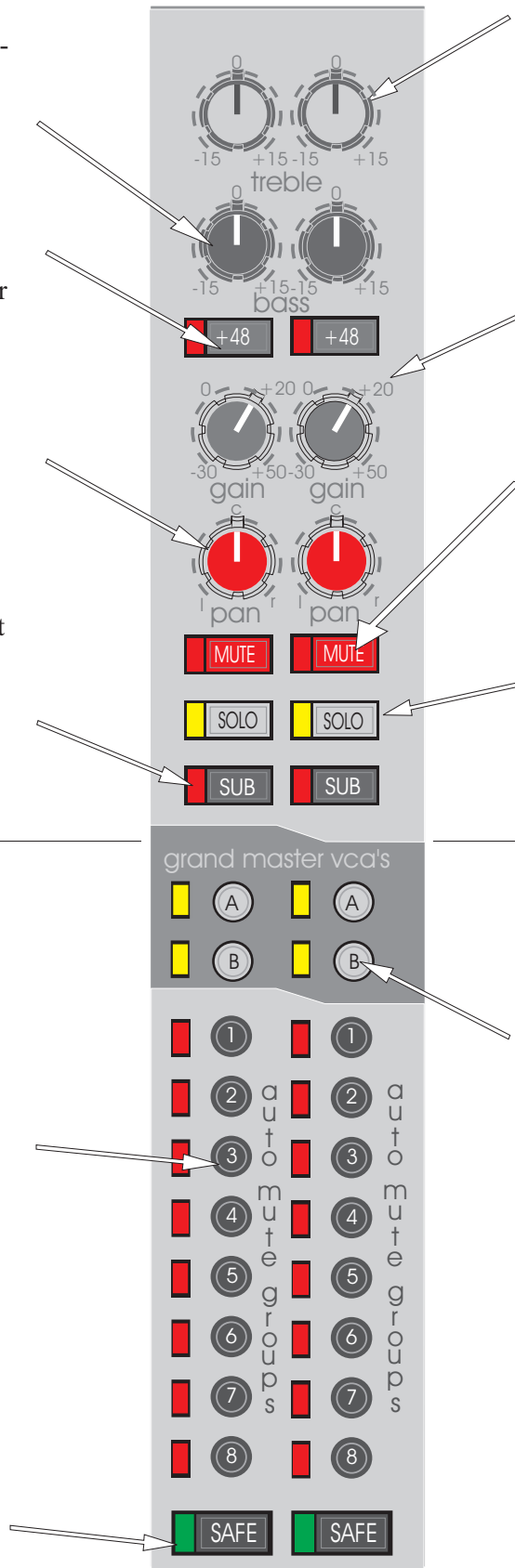

The GRAND MASTER VCA switches assign the audio sub groups to the 2 grand master vca sub groups.

# GROUPS

The INS switches connect the group insert return signals to the audio sub groups.

The ST switches connect the post fader audio sub group signals to the stereo master bus via the pan controls.

The group MUTE switches mute the audio groups at all points except the insert send and are under automation and automute group control.

The GROUP FADERS give continuous adjustment of the audio sub group levels from +

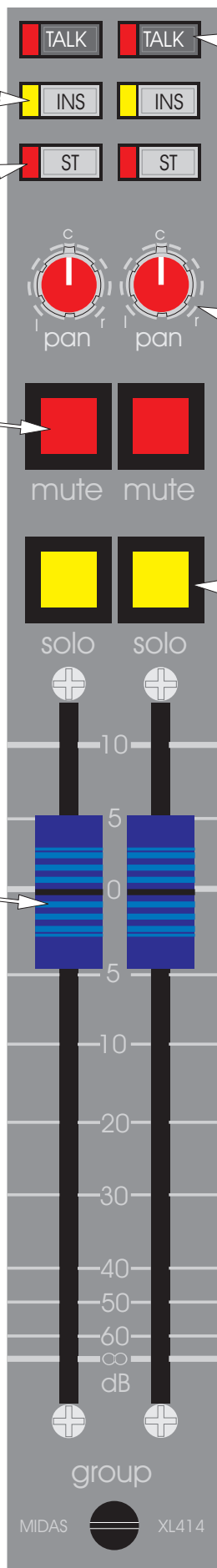

The TALK switches connect the audio sub groups to the COMMS module. When the TALK TO GROUPS switch on the COMMS module is activated it is then able to route its oscillator, pink noise, external input, talk mic or comms mic to the audio sub groups.

The group PAN controls place the audio groups within the stereo master mix and have a constant power law i.e. -3dB at the centre position.

The group SOLO switches send the group input signals to the mono PFL and stereo AFL busses. If a switch is pressed for a short time it will latch on or off, but if it is held on for more than 1 second the latching is disabled and when the switch is released the solo will turn off.



# MIDAS XL412

## Group Pod

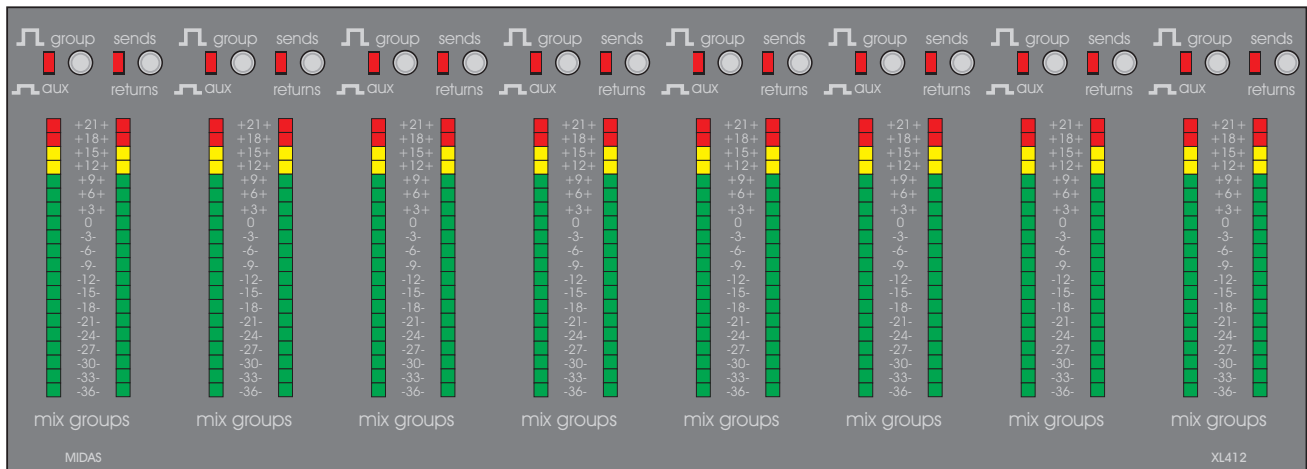

FUNCTION: To meter 16 group outputs, 16 aux master sends and 16 line level returns.

The AUX switch changes the function of the left and right meters so that they monitor the aux send outputs in place of the audio group outputs.

The METERS monitor the peak signal level of the group, aux or returns as described above but when the GLOBAL METER CHANGE OVER switch on the COMMS module is activated the meters monitor the group bus, aux bus or line return input amplifiers ( which ever is selected ).

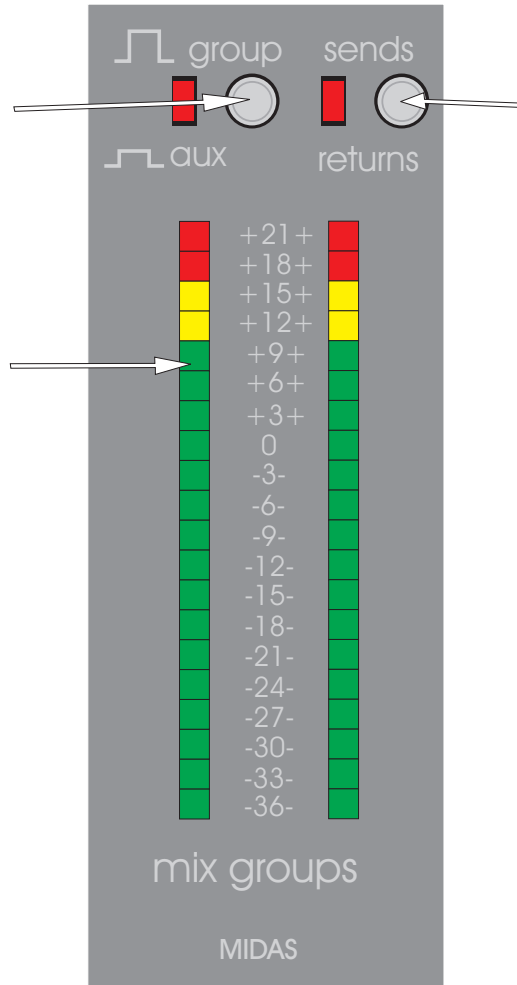

The RETURN switch changes the function of the left and right meters so that they monitor the post fader line return signals. If the AUX switch is not activated the meters return to monitoring the audio group outputs regardless of the RETURN switch position.

# MIDAS XL413

## Grand Master A

### VCA Fader

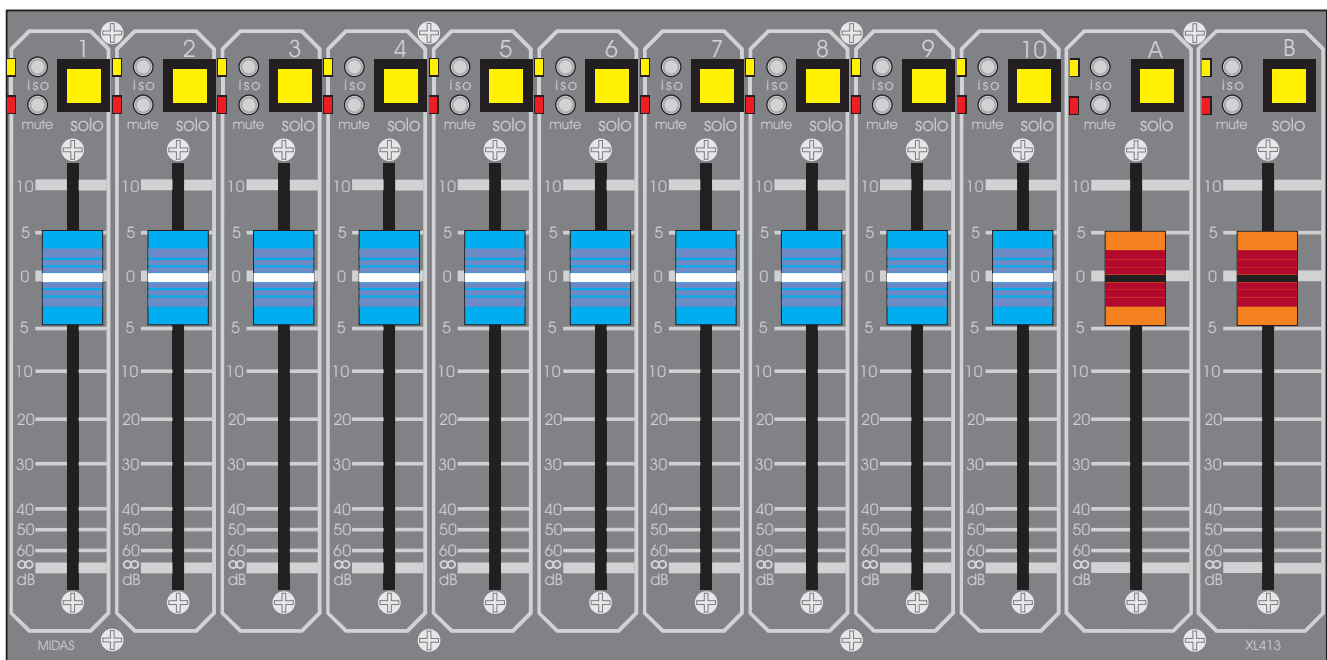

FUNCTION: Moving fader control of 10 VCA sub groups and 2 grand masters with facility to meter and solo listen.

The ISOlate switches disconnect the vca sub group faders and mutes from automation screen recall. Screen storage is still active.

The vca MUTE switches mute any post fader input channel signals which are assigned to the corresponding

The VCA GROUP faders are motorised and under automation control. They give continuous adjustment of the vca sub group gains from +10dB to off.

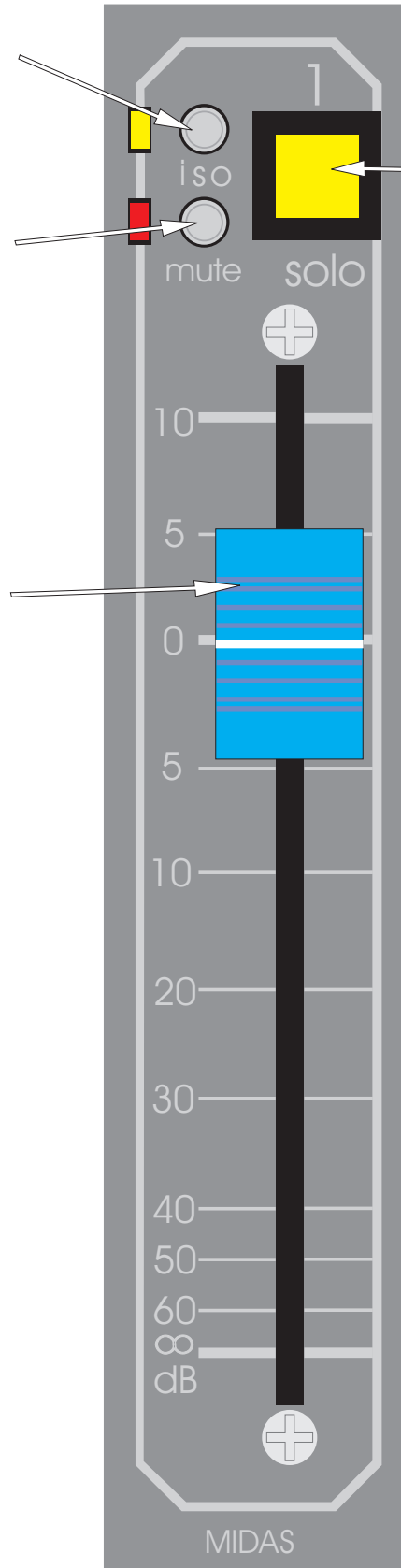

The vca SOLO switches are used to monitor VCA sub groups by creating a corresponding AUDIO sub group on the stereo AFL busses. All input channels and line returns that are assigned to a specific vca sub group will be summed onto the solo busses when that vca solo is active.

Note i. If large numbers of inputs are assigned to one vca sub group, there will be a higher than usual signal level sent to the solo busses when the vca solo is active (+ 6 to + 10 dB approx.).

Note ii. When vca solo switches are active the PFL buss also receives signals from the vca sub group inputs but it will NOT be a true representation of the relative levels within the vca sub group. This feature is however useful as it allows confirmation of signal present and signal quality when the vca fader is down or the vca sub group is muted. It is therefore important to know the status of the PFL MONITOR switch on the COMMS module before using the vca solo switches.

Note iii. If a vca solo switch is pressed for a short time it will latch on or off, but if it is held on for more than 1 second the latching is disabled and when the switch is released the solo will turn off.

The ISOLate A and B switches disconnect the grand master vca A and B sub group faders and mutes from automation screen recall. Screen storage is still active.

The vca MUTE A and B switches mute any AUDIO group post fader signals which are assigned to the grand master A or B vca sub groups.

The grand master A and B VCA GROUP faders are motorised and under automation control. They give continuous adjustment of the grand master vca sub group gains from +10dB to off.

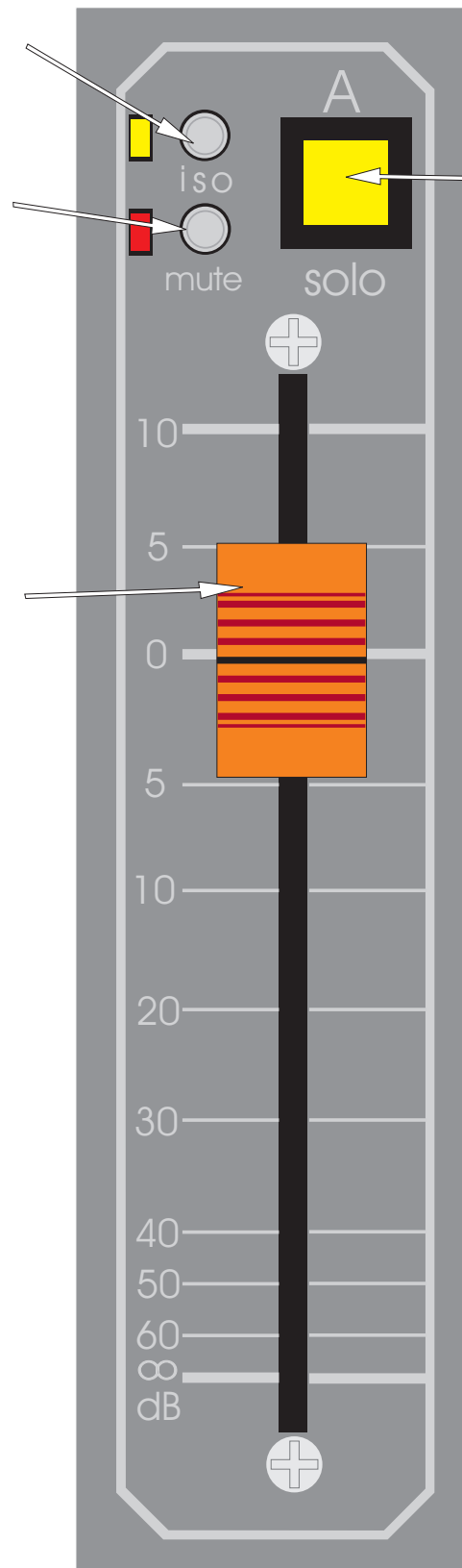

The grand master A and B vca SOLO switches are used to monitor the grand master A and B VCA sub groups by creating a corresponding AUDIO sub groups on the stereo AFL busses. All AUDIO sub groups that are assigned to grand master vca A or B will be summed onto the solo busses when the vca solo is active.

Note i. When a grand master vca solo switch is active the PFL buss also receives signals but they are NOT a true representation of the relative levels within the grand master vca sub group. This feature is however useful as it allows confirmation of signal present and signal quality when the grand master vca fader is down or muted. It is therefore important to know the status of the PFL MONITOR switch on the COMMS module before using the grand master vca solo switches.

Note ii. If a grand master vca solo switch is pressed for a short time it will latch on or off, but if it is held on for more than 1 second the latching is disabled and when the switch is released the solo will turn off.



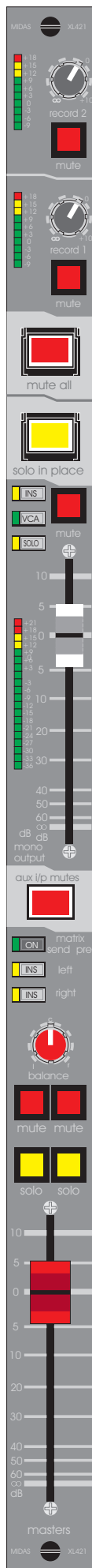

# MIDAS XL421 Master Module

The record METERS monitor the peak signal level of the left and right record outputs (which ever is the highest ).

The RECORD controls ( 1 and 2 ) give continuous adjustment of the stereo record outputs from + 10dB to off. The record signals are derived from the pre insert master left and right signals.

The record MUTE switches mute the record outputs.

The MUTE ALL switch effectively switches the console off by muting all outputs.

The SOLO IN PLACE switch disconnects the three pre insert master signals ( left, mono and right ) and replaces them with the stereo AFL solo busses. This does not effect the master to matrix feeds which means the matrix mixes can be "solo in placed" on the master outputs.

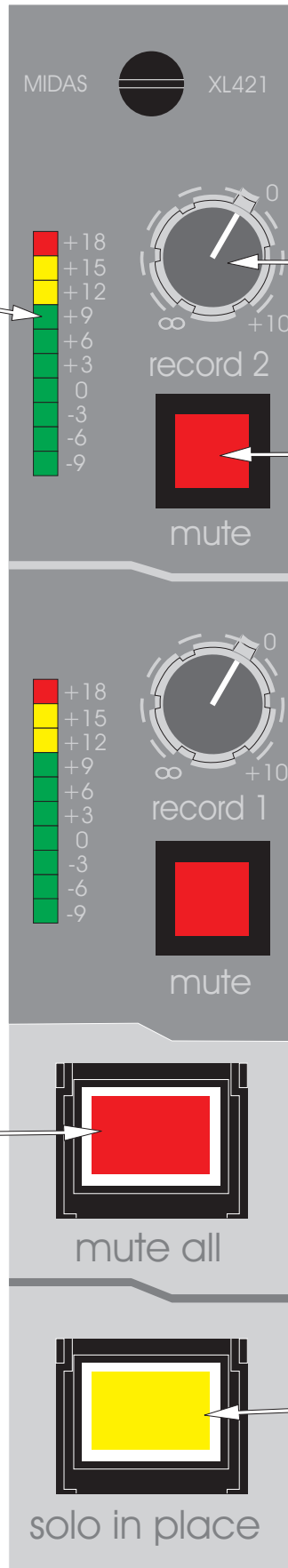



The mono INS switch connects the mono insert return signal to the mono mix.

The VCA switch connects the mono vca fader to the stereo master fader so that the mono output tracks any changes of the stereo master fader.

The mono SOLO switch sends the mono master signal to the PFL and AFL solo busses. If the switch is pressed for a short time it will latch on or off, but if it is held on for more than 1 second the latching is disabled and when the switch is released the solo will turn off. The master mix signal can not be sent to the solo busses while any other solo is active.

The mono METER monitors the peak level of the post fader mono signal. When the GLOBAL METER CHANGE OVER switch on the COMMS module is activated the meter monitors the mono bus summing amplifier output.

The mono MUTE switch mutes the mono output but not the mono insert send. This switch is under automation control.

The mono FADER gives continuous adjustment of the mono output level from + 10dB to off.

The AUX I/P MUTE mutes every aux line return input on the GROUP modules.

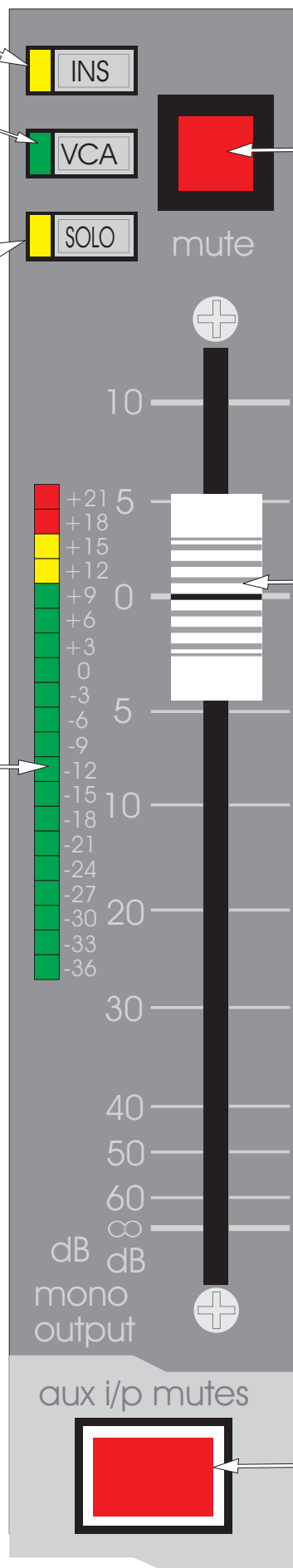

MATRIX SEND PRE. Feeds to the matrix modules from the stereo busses are post fader as a default. When the MATRIX SEND PRE is active, the feed changes to pre fader and pre insert.

The INS LEFT and RIGHT switches connect the master left and right insert return signals to the stereo master mix.

The stereo master SOLO switches send stereo master signals to the PFL mono and AFL stereo busses. If the switch is pressed for a short time it will latch on or off, but if it is held on for more than 1 second the latching is disabled and when the switch is released the solo will turn off. The master mix signal can not be sent to the solo busses while any other solo is active. This means that they can be left on to provide a stereo master signal in the headphones which will be overridden if any other solo is activated on the console.

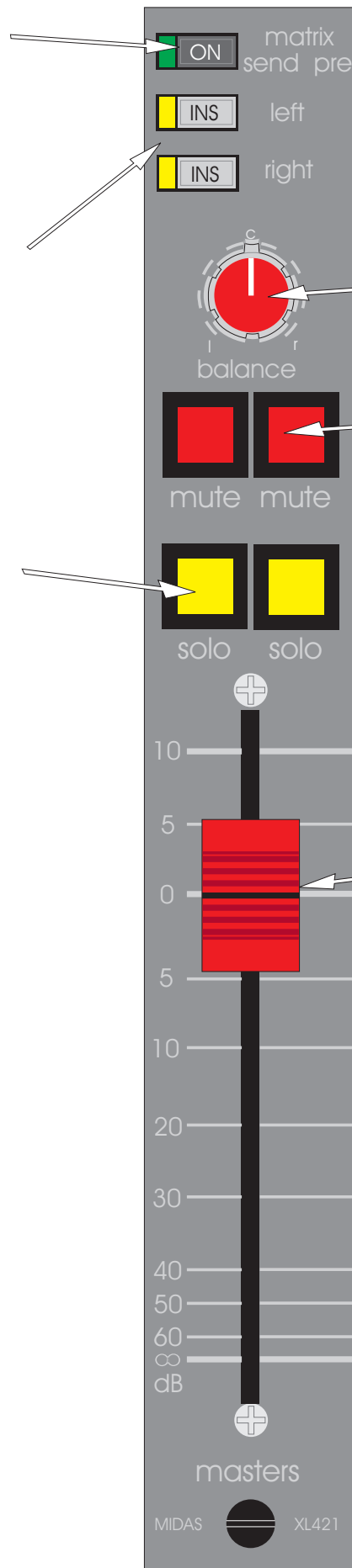

The BALANCE (pan) control gives continuous and reciprocal adjustment of the stereo left and right signal levels by + 3dB to off. This allows fine adjustment of the left, right power levels and imaging.

The stereo master MUTE switches mute the stereo master outputs but not the insert sends. These switches are under automation control.

The stereo MASTER FADER gives continuous adjustment of the stereo master mix level from + 10dB to off.

# MIDAS XL422

## Master Pod

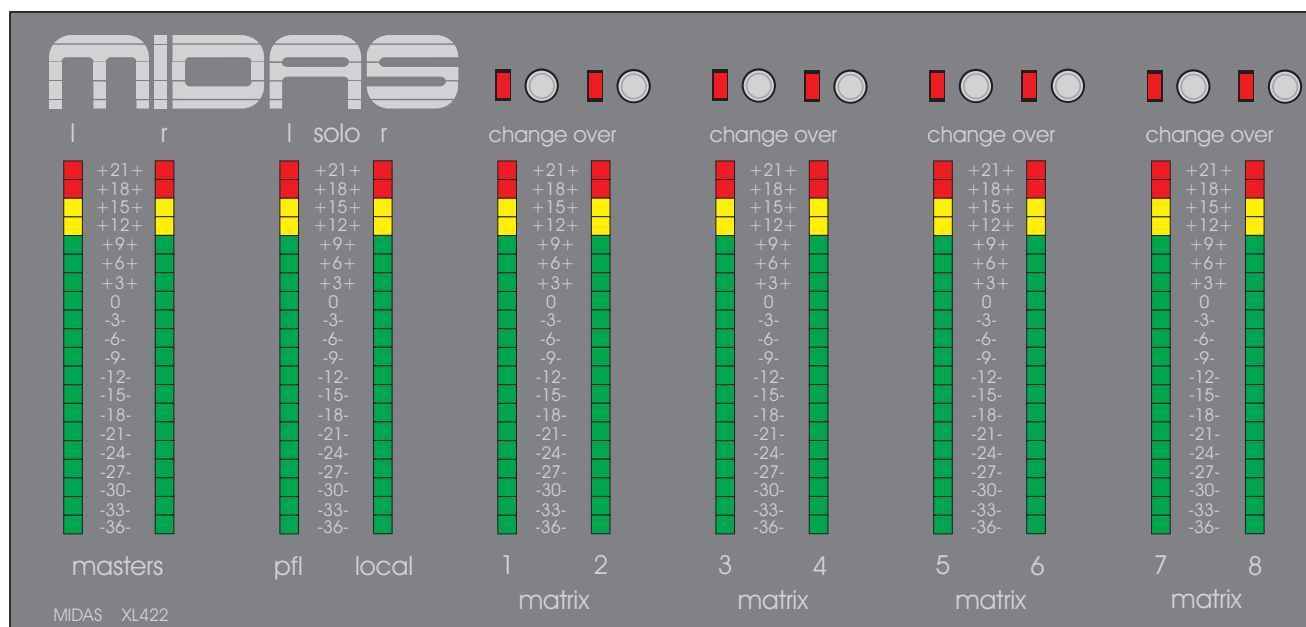

FUNCTION: Metering for master stereo, solo, PFL and local busses plus matrix outputs and stereo aux send outputs.

# Master Stereo Bus Metering

The METERS monitor the peak signal levels of the stereo master left and right outputs. When the GLOBAL METER CHANGE OVER switch on the COMMS module is activated the meters monitor the master left and right bus amplifiers.

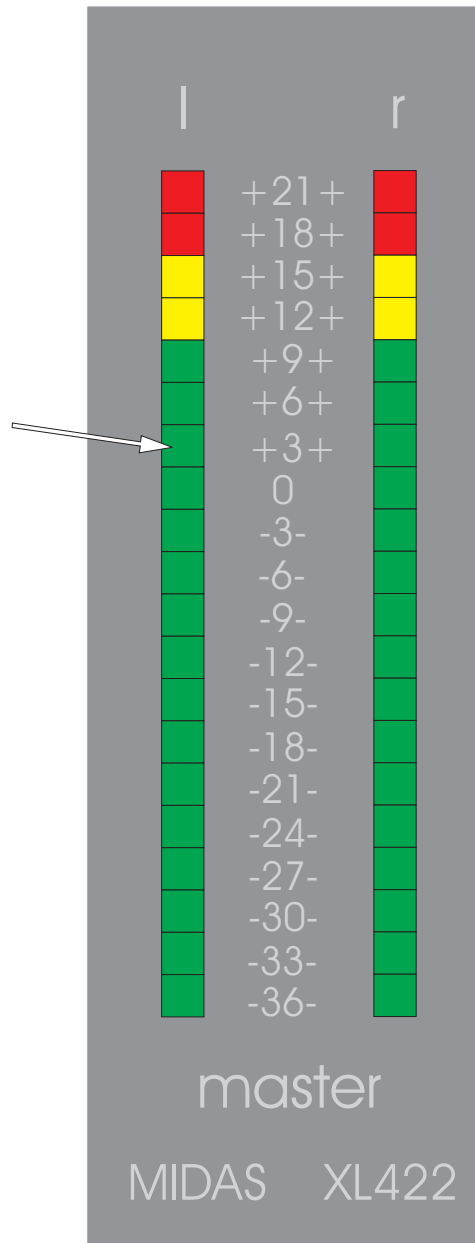

# Solo, PFL and Local Metering

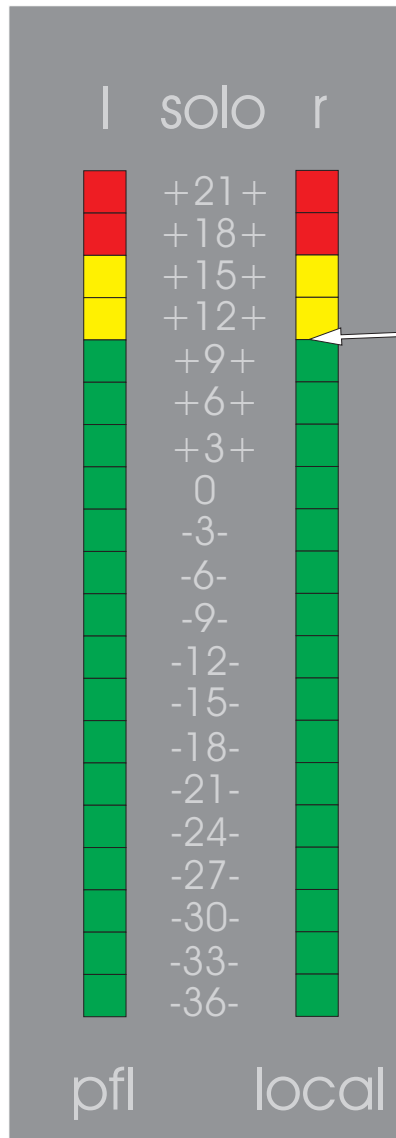

The meters monitor the peak signal level of the stereo AFL left and right solo busses or the PFL and local output level. The change over is automatic as part of the PFL Monitor switch on the COMMS module.

# Matrix and Stereo Master Aux Send Metering

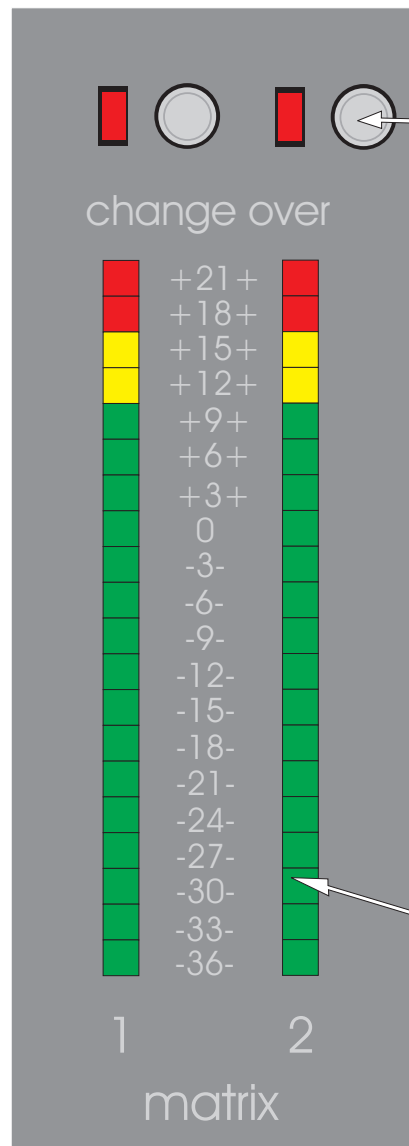

The CHANGE OVER switches change the function of the left and right meters so that they monitor the stereo aux send outputs in place of the matrix outputs.

The METERS monitor the peak signal level of the matrix or stereo aux outputs as described above but when the GLOBAL METER CHANGE OVER switch on the COMMS module is activated the meters monitor the matrix bus or stereo aux bus amplifiers ( which ever is selected ).

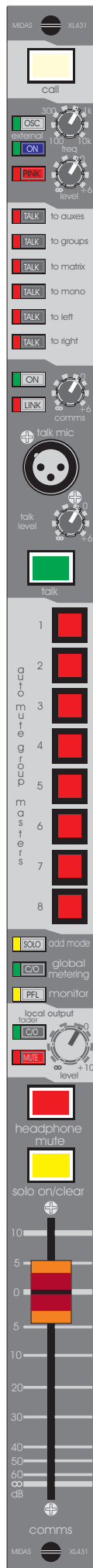

# MIDAS XL431 Communications Module

The OSC switch connects the oscillator to the talk system.

The EXTERNAL ON switch connects the external talk input and output to the talk system.

The PINK noise switch connects pink noise to the talk system.

The TALK TO AUXES switch sends the talk system signals to ALL the aux busses.

The TALK TO MATRIX switch sends the talk system signals to any matrix buss which have their MATRIX module TALK switch active.

The TALK TO LEFT switch sends the talk system signals to the left master bus.

The COMMS ON switch sends the comms headset mic amplifier signal to the comms

The LINK switch connects the talk system into the comms system so that talk mic, headphones and local output can send and receive ( respectively ) "clearcom" signals as well as the headset.

The TALK switch activates the talk mic on the talk system and dims the local outputs by 20dB to stop howl round. When in LINK mode the COMMS ON switch activates the talk mic on the comms system and the side tone cancel circuit stops howl round.

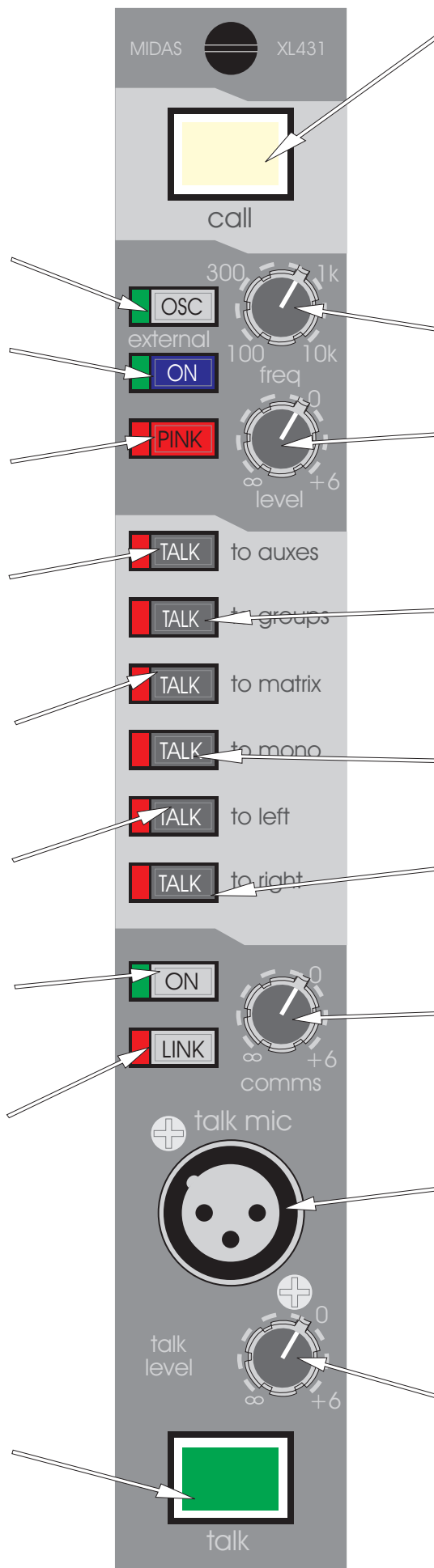

The CALL switch and indicator has two functions:-

- i. It illuminates when an incoming "clearcom" call is expected.
- ii. It fires a DC pulse when pressed to signal "clearcom" devices (by illuminating their call lamps) that an outgoing call is to be made.

The FREQ control gives continuous adjustment of the oscillator frequency from 100Hz to 10K.

The talk LEVEL control gives continuous adjustment of all the talk inputs except the talk mic and has a range from + 6dB to off.

The TALK TO GROUPS switch sends the talk system signals to any group buss which have their GROUP module TALK switches active.

The TALK to MONO switch sends the talk system signals to the mono master bus.

The TALK TO RIGHT switch sends the talk system signals to

The COMMS control gives continuous adjustment of the "clearcom" signal levels sent to the headset, headphones and local output. The level adjustment is from + 6dB to off.

The TALK XLR socket accepts balanced 150 Ohm microphone signals from - 50dBu to - 20dBu and uses an auto ranging gain system to bring the level to nominal 0dBu line level.

The TALK control gives continuous adjustment of the talk mic amplifier signal from + 6dB to off. The talk control does not act on signals sent to the comms system in LINK mode.



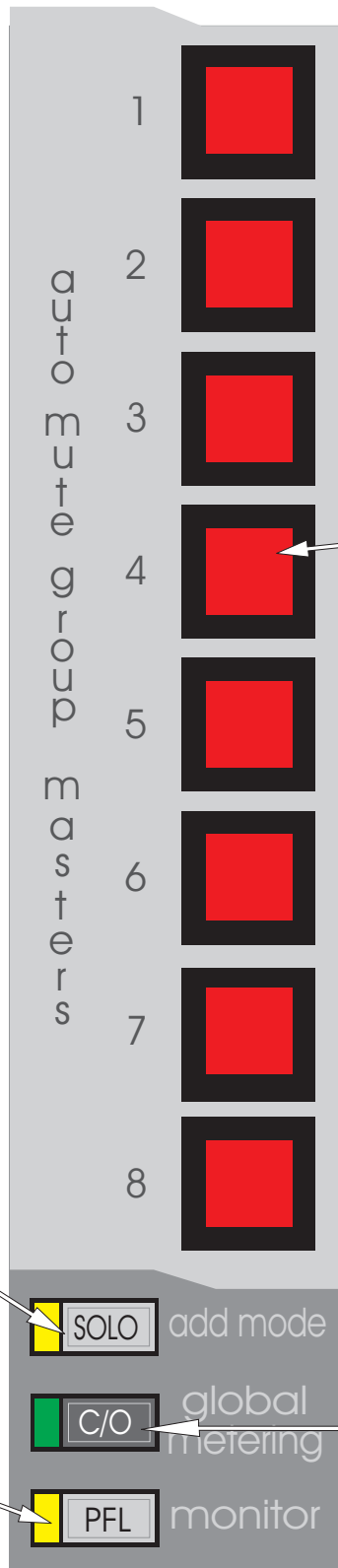

The AUTO MUTE GROUP MASTER switches ( 1 to 8 ) activate the mute circuits on any appropriately mute group assigned input channel or audio group.

The SOLO ADD MODE switch allows multiple channel access to the solo busses. When the solo add mode is off the action of pressing a solo switch will cancel any other active solo except for the master solo switches where the canceling effect is only temporary ( see XL421 Master Module on page 28 ).

The PFL MONITOR switch sends the mono PFL solo bus signal to the headphones and local outputs in place of the stereo AFL solo bus signals.

The GLOBAL METER CHANGE OVER switch changes the operation of every meter on the console except the comms meters and the record meters. The "normal" meter operation is to monitor pre fader on input channels and post fader on all other signals. When the global meter change over is active the meters change to monitor input amplifiers or bus amplifiers ( as appropriate ) on all signals.

The FADER CHANGE OVER switch swaps the local output level control and mute with the headphone fader and mute.

The local output MUTE switch mutes the local

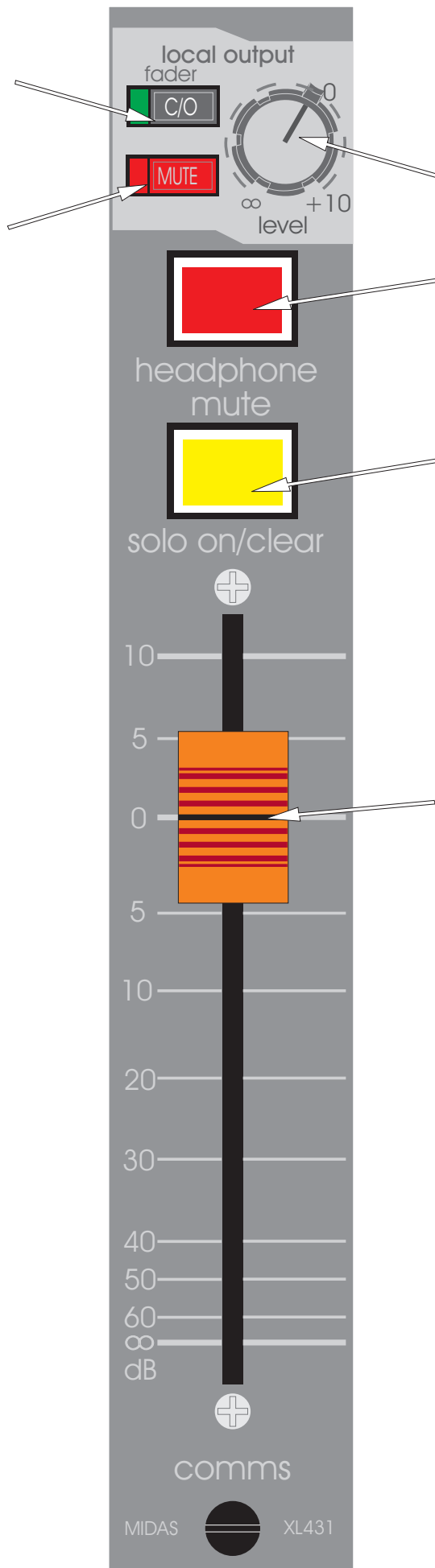

The local output LEVEL control gives continuous adjustment of the local output

The HEADPHONE MUTE switch mutes the headphone outputs.

The SOLO ON / CLEAR switch and indicator has two functions:-

- i. It illuminates when any solo switch (except a master solo switch) is active.
- ii. When pressed it clears any active solo switches (except master solo switches).

The HEADPHONE fader gives continuous adjustment of the headphone level from + 10dB to





# MIDAS XL441 Matrix Module

The stereo aux MUTE switch mutes the stereo aux outputs.

The stereo aux SOLO switch sends stereo aux signals to the PFL mono and AFL stereo busses. If the switch is pressed for a short time it will latch on or off, but if it is held on for more than 1 second the latching is disabled and when the switch is released the solo will turn off.

The MIX controls ( 1 to 16 ) give continuous adjustment of the audio sub group levels sent to the matrix mixes from + 6dB to off. If the FADER CHANGE OVER switch on the GROUP module is active the mono aux bus will route to the matrix mix in place of the audio sub group.

The STEREO AUX MASTER control gives continuous adjustment of the stereo aux output level from + 10dB to off.

The MTX switch sends the pre fader stereo aux bus signals to the matrix mix directly below so that the console can be used for monitor applications.

The GLOBAL PRE ON switch changes the audio sub group signals that are routed via the mix controls to the matrix from post fader to pre fader.

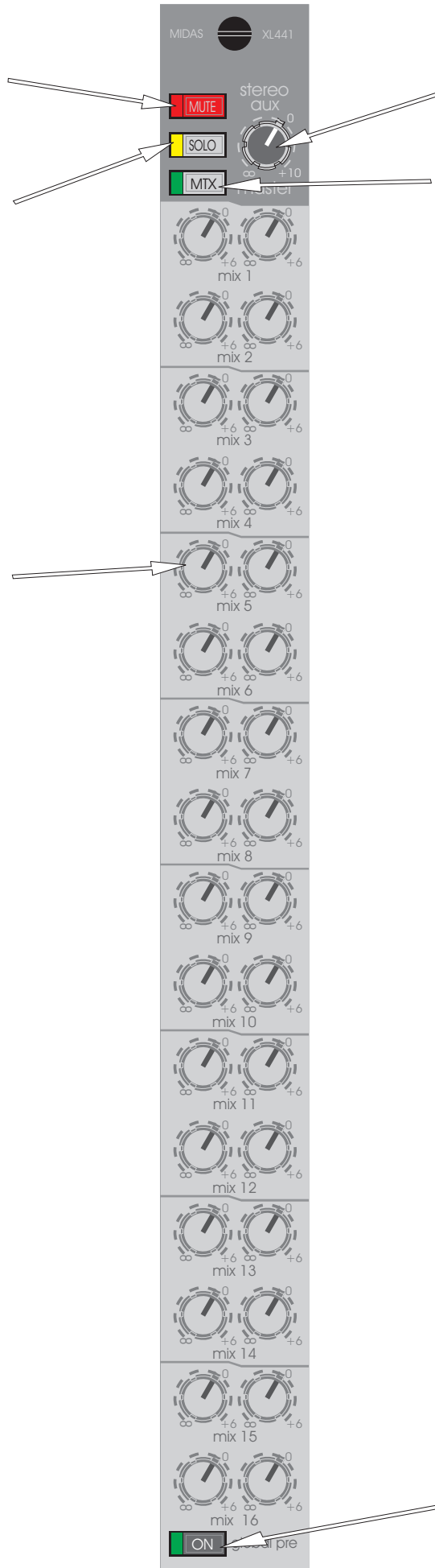

The MASTER LEFT controls give continuous adjustment of master left signals that are sent to the matrix mixes. The adjustment is from +6dB to off.

The TALK switches connect the matrix busses to the COMMS module. When the TALK TO MATRIX switch on the COMMS module is activated it is then able to route its oscillator, pink noise, external input, talk mic or comms mic to the matrix mix.

The MATRIX FADERS give continuous adjustment of the matrix levels from +10dB to off.

The MASTER RIGHT controls give continuous adjustment of master right signals that are sent to the matrix mixes. The adjustment is from +6dB to off.

The INS switches connect the matrix insert return signals to the matrix mixes.

The matrix MUTE switches mute the matrix outputs but not the insert sends. These switches are under automation control.

The matrix SOLO switches send signals to the PFL mono and AFL stereo busses. If the switch is pressed for a short time it will latch on or off, but if it is held on for more than 1 second the latching is disabled and when the switch is released the solo will turn off. These solo switches can not be operated if the console is being used in SOLO IN PLACE mode. This is a safety feature which prevents matrix output signals from being routed back to their inputs via the master matrix feed.

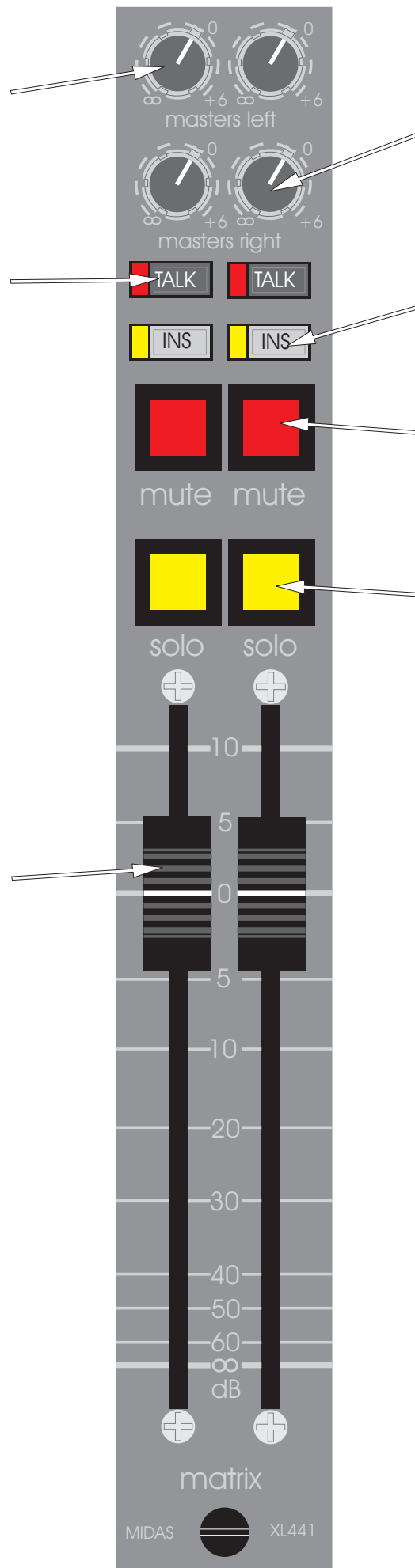

# MIDAS XL443

## Automation Control

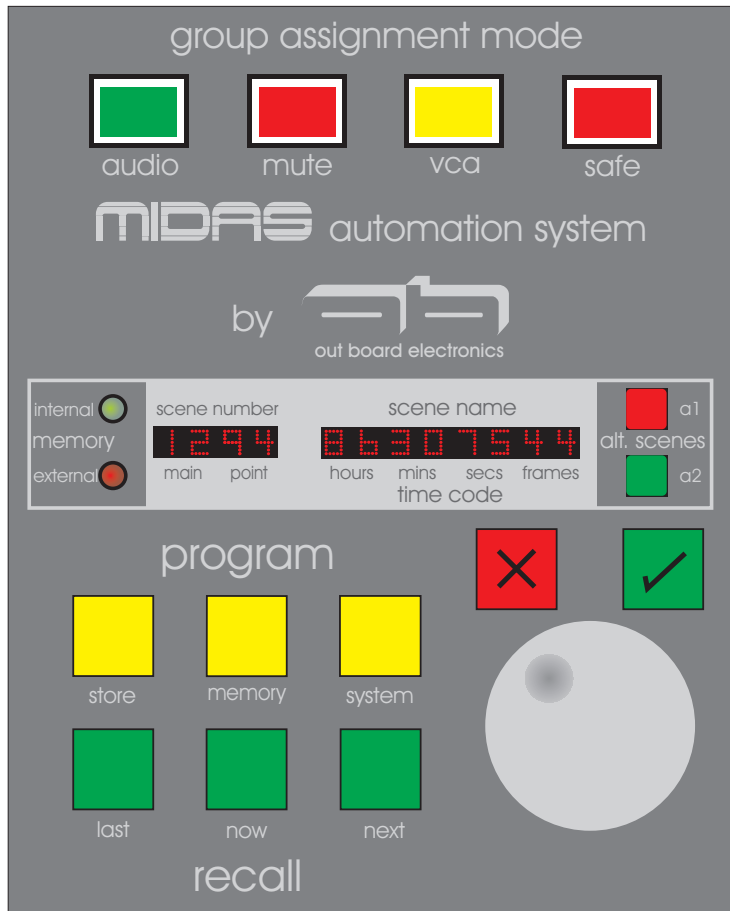

## VCA, Audio and Automute Group Assign

1. The AUDIO switch changes the function of every GROUP ASSIGN SWITCH and its corresponding LED indicator on the INPUT channels so that AUDIO group assignment can be viewed or changed.
2. The VCA switch changes the function of every GROUP ASSIGN SWITCH and its corresponding LED indicator on the INPUT channels so that VCA group assignment can be viewed or changed.
3. The MUTE switch changes the function of every GROUP ASSIGN SWITCH and its corresponding LED indicator on the INPUT channels so that MUTE group assignment can be viewed or changed.
4. The SAFE switch changes the function of the audio, vca, and mute switches above so that the groupings can be viewed only. i.e. all GROUP ASSIGN SWITCH on the INPUT channels will be disabled.





# **MIDAS XL4 Automation system**

## **System operation**

while every effort has been made to ensure it is accurate, there may be changes dependent on the software version. This has been written for Version 25.A

Should you find an error, or you find a section ambiguous, please let MIDAS know so that we may correct the problem.

## Information about this manual

In this document the following colours have been used to aid the text:

Descriptions of what can be seen on the Alpha-numeric displays are in green, such as **‘OVERSTORE’**.

When a button is referred to, its name is in blue, such as **‘STORE’**.

Functions or operation names are in red, such as **‘SCENE NAME’**.

Warnings and important notes have their headings in magenta, such as **‘WARNING’**.

## Contents

<b>Introduction.</b>	5
Automation system overview.	5
The Central control unit.	6
<b>Operating the system.</b>	7
Input fader mode control.	7
System Start Up	7
Unlock The Automation System	7
Scene Storage	8
Scene Recall	8
<b>System menu</b>	9
Unlock	9
Lock	9
Chmidiout	10
Chmidin	10
Automidi	10
RSLink	10
Faders	10
Mutes	10
Matrix	10
Contacts	10
XL4 Size	11
Mem Size	11
Format	11
Test 1	11
Test 2	11
Test 3	11
Test 4	11
Open	11
Restrict	11
Totclear	11
<b>Total Clear Format Procedure</b>	12
<b>Store Menu</b>	15
New Scene	15
Overstoring	16
X-FADE (Crossfade).	16
Expand	16
Insert.	16
Delete.	16
Copy.	16
Edit.	16
Edit scene name.	16
Edit MIDI In	17
Midi Clear	17
Edit midi Out	17

## Contents Cont.

<b>Memory menu.</b>	18
Toggle	18
Internal.	18
External.	18
Copy all.	18
Clear all.	18
<b>Alternate Buttons</b>	19
<b>Using the system - general hints and tips.</b>	19

## Introduction.

### **Automation system overview.**

The **MIDAS XL4** is an 'intelligent' live mixing console. It utilises microprocessor technology to provide the operator with unprecedented features for a live console, whilst remaining easy to use and retaining the familiar look of a normal console.

The update speed of the **MIDAS XL4** automation was a high priority of the system design, the entire console is capable of updating itself over fifty times a second. Thus the delay between pressing the 'RECALL' button and the desk update is negligible.

Some sound engineers harbour concerns about giving control of a sound system over to computers, in the case of the **MIDAS XL4** these concerns are unfounded. For one thing, the **MIDAS XL4** is a 'computer assisted' console. Most of the audio functions may be controlled without the aid of microprocessors, and all audio functions may be controlled without the central control CPU.

With the exception of the central controller CPU, the microprocessor chips used are 'single chip micro's' or 'microcontrollers'. The CPU, program memory, RAM, data converters and timers are all housed in a single chip. This gives the utmost in reliability as the 'computer' itself is protected from the outside world by it's input/output ports.

Fifty microprocessors (in a standard 48 input console) split the workload, resulting in high speed operation and also providing the large degree of protection required for live performances. Should one microprocessor 'fall over' the others will continue to operate normally.

In addition, the system has been designed in such a way that if a microprocessor does fail, the audio circuits controlled by that unit will usually remain active in the state last recalled. The chances of a microprocessor failing in such a way as to reconfigure its audio control circuits are extremely remote. The most likely indication that a microprocessor has failed will be that it fails to respond to the central control CPU. The audio circuits will continue to work.

Important controls such as the MUTE switch, whilst they can be over-ridden by microprocessor control, will work without the intervention of a microprocessor.

Each input channel has its own microprocessor, the VCA master section has one and the final microprocessor is in the central control section.

All the microprocessors are located in the fader bay of the XL4. No audio passes through the fader bay, allowing a high degree of immunity to digital breakthrough to be achieved.

The use of multiple processors also means that the software, instead of being one large program, is broken up into a number of small programs which are easier to test and debug, minimising the chances of software problems.

## The Central control unit.

The **MIDAS XL4** Automation is controlled from the central control CPU mounted to the right of the VCA Master faders.

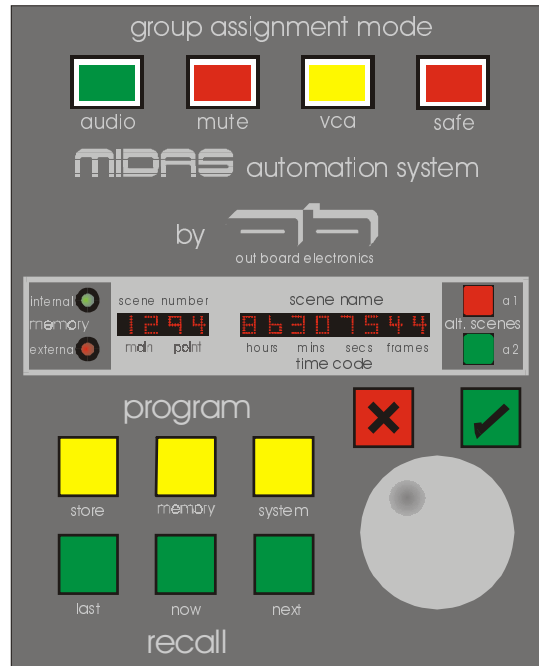

The top four switches, labelled 'AUDIO', 'MUTE', 'VCA' & 'LOCK' are not directly part of the central control CPU, these switches directly control the operating mode of the input fader automation. (See **Input fader mode control**, later).

The central controller CPU has been developed by OUTBOARD ELECTRONICS Ltd. in conjunction with MIDAS. The operation of the **MIDAS XL4** Automation system is based on the control system used on the OUTBOARD ELECTRONICS SS20 Moving fader system. Many operators used to the SS20 will find operating the **MIDAS XL4** Automation system very familiar.

Control of the system is achieved with eight buttons and a 'jogwheel'. Operator feedback is done with two displays, a four character 'scene number' display and an eight character 'scene name' display.

Auxiliary functions are accessed through a series of menus.

The main 1 Meg of internal memory is battery backed up and may also be downloaded on to a memory card.

## Operating the system.

### Input fader mode control

The top four switches of the central control unit, labelled 'AUDIO', 'MUTE', 'VCA' & 'LOCK' directly control the operating mode of the input fader automation.

With the 'AUDIO' mode enabled, the fader bay switch bank controls the audio group routing. Only switches 1-8 are used. Switches 9 & 10 are used to trigger a input moving fader calibration on the input channel (when fitted, if no moving fader is fitted the function will time out). To use this function press switch 9. The LEDs associated with switches 9 & 10 will flash. This indicates that the clear function is 'armed'. Pressing switch 10 will clear the channel.

If switch 9 is pressed, arming the calibrate function, and it is not desired to calibrate the channel, pressing switch 9 again will disarm the clear function.

With the 'MUTE' mode enabled, the fader bay switch bank controls the automute assignments. Only switches 1-8 are used for automutes. Switches 9 & 10 are used for the channel clear function.

The channel clear function resets all computer controlled settings on that channel to off. To use this function press switch 9. The LEDs associated with switches 9 & 10 will flash. This indicates that the clear function is 'armed'. Pressing switch 10 will clear the channel.

If switch 9 is pressed, arming the clear function, and it is not desired to clear the channel, pressing switch 9 again will disarm the clear function.

With the 'VCA' mode enabled, the fader bay switch bank controls the VCA assignments.

When the system is 'locked' (with the 'LOCK' switch illuminated) the three operating modes may be called up, allowing the state of the switches to be seen, but the switches will not operate. This is to prevent accidental operation of the fader bay switches.

### SystemStart up

Following power up, the alpha-numeric display will briefly show the software release version, followed by 'READY'. This indicates that the initialisation is complete and the system is ready for use.

The system powers up in the 'locked' state. In this state scenes may be recalled but not stored. All functions which modify the stored data are disabled until the system has been unlocked.

### Unlocking The System

To unlock the system after start up the following procedure must be followed. Press the **SYSTEM** button and **UNLOCK** will be displayed in the right hand screen. Press the **YES** button and the left hand window will change to read 1200, using the jog wheel alter this screen until the correct password is displayed. This password is found on the insert provided with this manual or can be obtained from Midas.

## Scene storage

Storing scenes may only be done when the system is unlocked.

To store a scene, first display the position you wish to store the scene in on the left hand window by using the jog wheel. Scene 0000 is a preset scene and can not be overstored. Once the required position is displayed press the **'STORE'** button. The display will respond with **'NEW'**, if the scene does not yet exist or **'OVERSTORE'** if the scene does exist.

Following a scene store operation, the scene number is incremented by 1 or 0.1 depending on whether the scene was expanded previously.

## Scene recall

Recalling scenes is achieved using the **'LAST'**, **'NOW'** and **'NEXT'** buttons, and also using the jogwheel.

Pressing the **'NEXT'** button causes the system to step to the next scene number in memory and recall it to the console. After the last scene has been recalled, pressing **'NEXT'** will cause the display to show **'END'** and no other operation will occur.

Pressing the **'LAST'** button causes the system to step to the previous scene number in memory and recall it to the console. After the first scene has been recalled, pressing **'NEXT'** will cause the display to show **'START'** and no other operation will occur.

Pressing **'NOW'** will recall the scene number currently shown in the left hand section of the display. This number may be adjusted using the jogwheel.

When the system is locked the jogwheel will only use the numbers of scenes that exist in memory.

No operations other than recall are available while the system is locked.

When the system is unlocked the jogwheel adjust the scene number in increments of one whether the scene exists or not. Attempting to recall a scene number which does not exist will result in the message **'EMPTY'**.



## System menu.

To call the system menu, press the '**SYSTEM**' button. The display will show '**SYSTEM**' and the '**SYSTEM**', '**NO**' and '**YES**' buttons will flash.

The jogwheel may then be used to scroll through the system options.

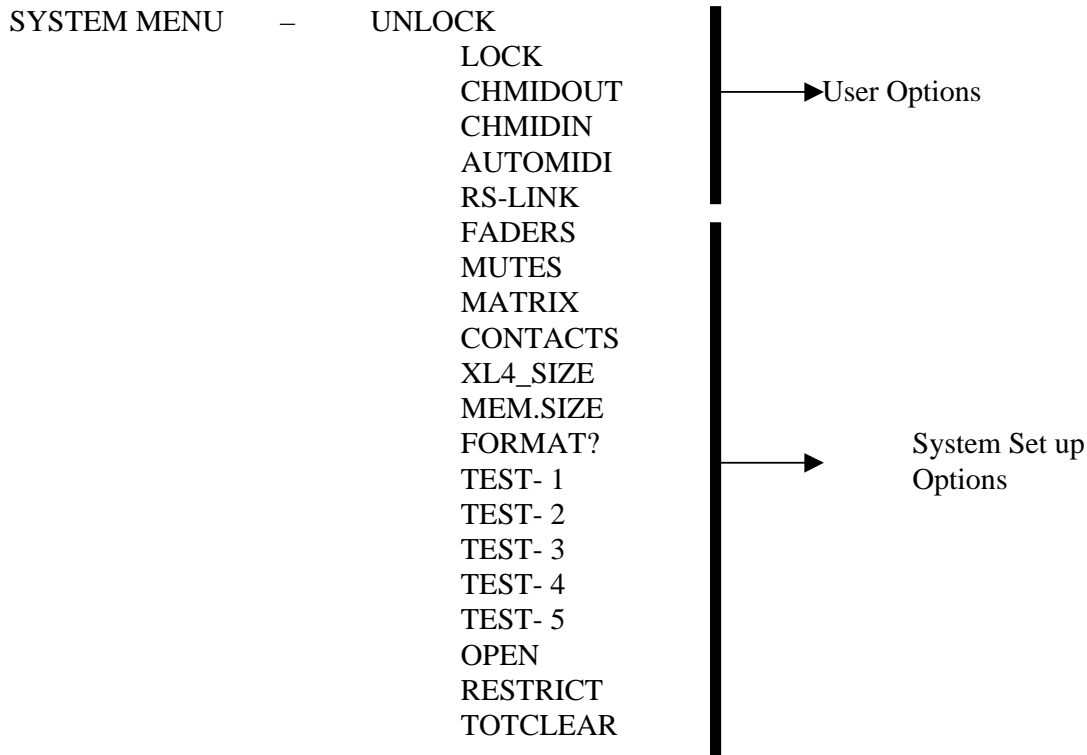

### **UNLOCK**

To unlock the system, press the '**YES**' button while the display is showing '**UNLOCK**'. The jogwheel may then be used to adjust the password number shown in the left section of the display.

When the correct password number is shown, press '**YES**'. If the number is accepted the display will briefly show '**OK**'. This indicates that the system is unlocked. The display will then return to showing the title of the current scene.

If the display returns directly to the scene title without showing '**OK**' then the number has not been accepted and the system is still locked.

### **LOCK**

To lock the system, rotate the jogwheel until the '**LOCK**' option is displayed. Pressing '**YES**' will then lock the system, this will be indicated by the display briefly showing '**DONE**'. The display will then return to showing the title of the current scene.

## **CHMIDOUT**

This option allows the output MIDI Channel to be selected. To set the channel number, press the **'YES'** button while the display is showing **'MIDI CH'**. The jogwheel can then be used to select the required channel. When the required channel number is displayed, press the **'YES'** button to enter it.

## **CHMIDIN**

This option allows the input MIDI Channel to be selected. This is the channel down which program changes can be sent that the XL4 will respond to when set up in the edit menu, see store menu. To set the channel number, press the **'YES'** button while the display is showing **'MIDI CH'**. The jogwheel can then be used to select the required channel. When the required channel number is displayed, press the **'YES'** button to enter it.

## **AUTOMIDI**

This function when enabled automatically places a midi out message with every scene stored (0 to 99 only). This message is sent out on the midi channel selected using the MIDI CH selection. For example if scene 0100 is stored after automidi is enabled, when recalled a program change one will be sent from the midi out port on the midi channel selected in **MIDI CH**.

## **RS-LINK**

This function allows you to enable and disable the RS link on the rear of the console (RS232-2). Pressing the **'YES'** button when this is displayed in the left hand display will then allow you to choose **YES** or **NO** using the jog wheel. Once you have chosen pressing **'YES'** will save your choice and drop you back out of the menu. This function is used when 2 XL4s are linked, enabling the one consoles automation to follow the others. You can either make one the consoles a master slave combination by disabling the RS232 in one console or control the recall of the automation from either console if they are both enabled.

## **FADERS**

This option is not used. However if the memory has been corrupted for some reason (during servicing for example) this value should be set to zero. This procedure is described in the total clear and format procedure.

## **MUTES**

This option is not used. However if the memory has been corrupted for some reason (during servicing for example) this value should be set to zero. This procedure is described in the total clear and format procedure.

## **MATRIX**

This option is not used. However if the memory has been corrupted for some reason (during servicing for example) this value should be set to zero. This procedure is described in the total clear and format procedure.

## **CONTACTS**

This option is not used. However if the memory has been corrupted for some reason (during servicing for example) this value should be set to zero. This procedure is described in the total clear and format procedure.

## **XL4 SIZE**

This number should be set to 48. However if the memory has been corrupted for some reason (during servicing for example) this value should be set to zero. This procedure is described in the total clear and format procedure.

## **MEM SIZE**

This number should be set to 31. However if the memory has been corrupted for some reason (during servicing for example) this value should be set to zero. This procedure is described in the total clear and format procedure.

## **FORMAT**

Once the system settings have been entered, this option is used to format the memory ready for use. This is done by pressing 'YES' when the display is showing 'FORMAT'.

### **Test 1**

This sets the speed of Test 2 and 3

### **Test 2**

This cycles through the scenes at a speed set by **Test 1**.

### **Test 3**

This is a continuous read/write test as a speed set by **Test 1**.

### **Test 4**

This is a system memory test, the automation control system will write and read to each bit of memory individually and check for any errors. This test is extremely time consuming and special equipment is needed to see any results as there is no decipherable error messages are shown on the display if a fault is found.

## **WARNING!**

During the test modes, the motorised faders should be disabled using the 'ISOLATE' switch. Allowing the faders to attempt to keep up with the test function for long periods may damage the servo drivers.

## **OPEN**

This allows you to enter the password which then enables access to the RESTRICT function in the menu. To access this press the YES button the left hand screen will then change to read 3200, using the jog wheel enter the correct password and press the YES button. This password is found on the insert provided with this manual or the separate password pdf provided.

## **RESTRICT**

This function is only accessible after the correct password has been entered into the OPEN option. This function allows Midas to look at the last 8 operations of the automation control system and was placed in for software debugging purposes.

## **Total Clear**

This function allows you to do a complete low level format of the automation control system memory. This procedure is shown next : **WARNING** if this procedure is carried out all user information will be lost.

## Total Clear and Format Procedure

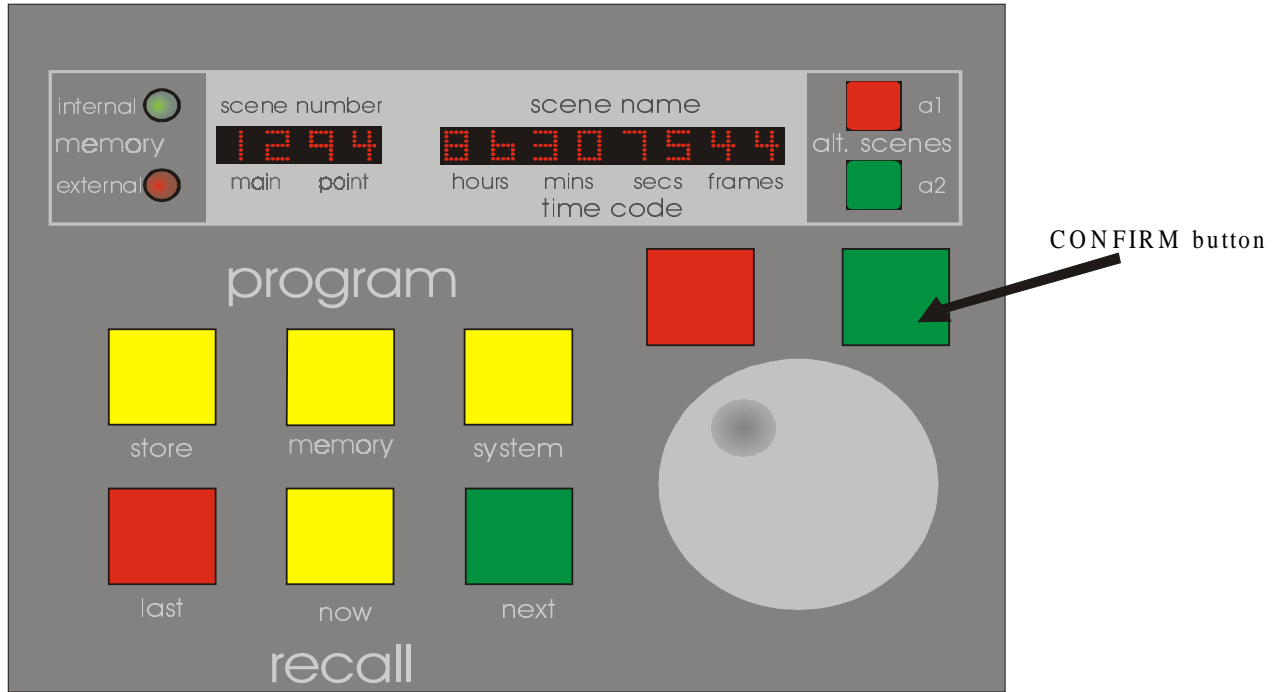

### TOTAL CLEAR AND FORMAT PROCEDURE

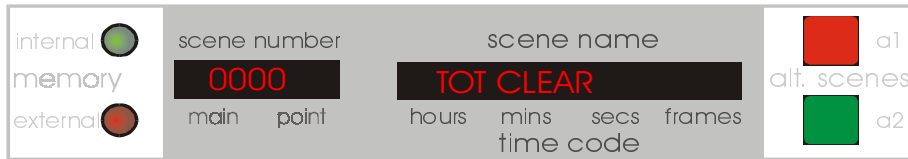

Press SYSTEM button on CPU panel  
Scroll to TOT CLEAR and press CONFIRM (large green button)

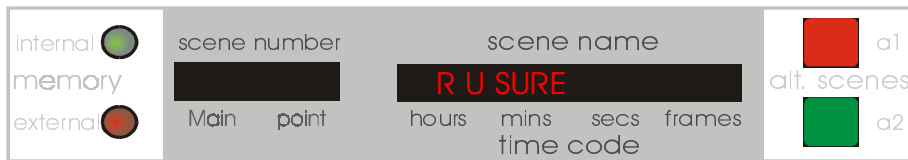

Display prompts R U SURE, press CONFIRM

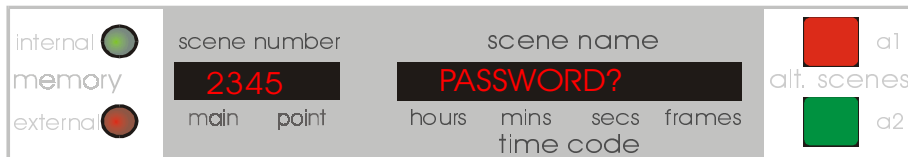

Then at PASSWORD? prompt, scroll to 2345 and CONFIRM

Midas XL4 Automation system

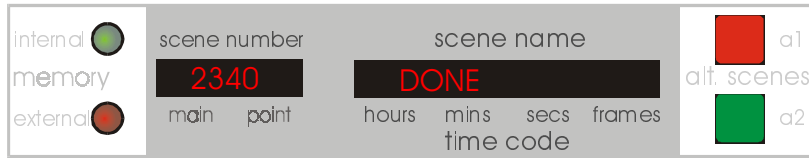

Display prompts TOTAL CLEAR, then WAIT, then DONE

Reset the console by turning power off/on or by pressing the reset button within the vent below the card socket.

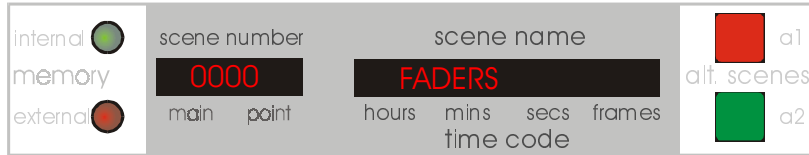

Press SYSTEM, Scroll to FADERS, Press CONFIRM

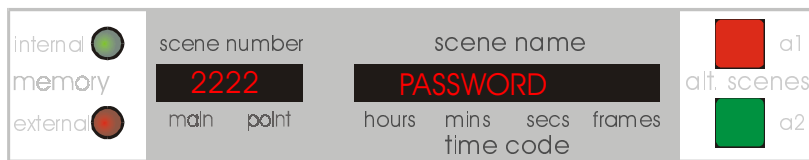

Display prompts 2222 PASSWORD?

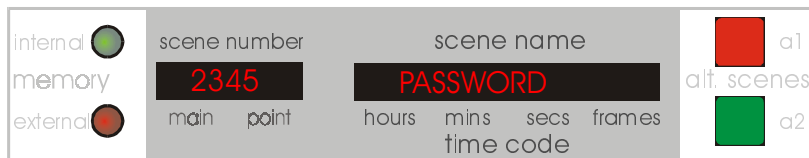

Scroll to 2345, Press

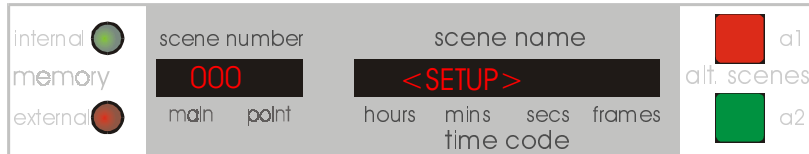

Display prompts FADERS then 000 SETUP, Press CONFIRM

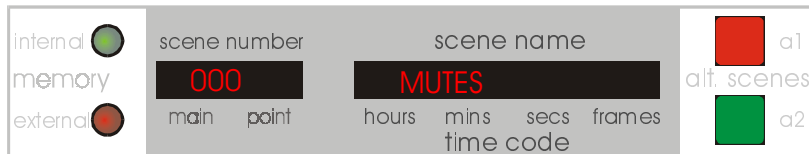

Scroll to MUTES, Press CONFIRM, display prompts 000 SETUP, press CONFIRM

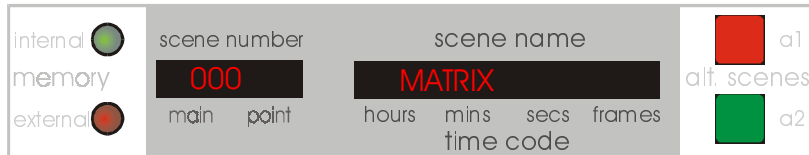

Scroll to MATRIX, Press CONFIRM, display prompts 000 SETUP, press CONFIRM

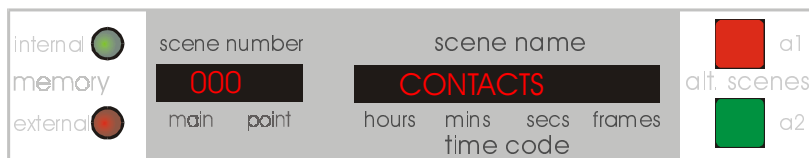

Scroll to CONTACTS, Press CONFIRM, display prompts 000 SETUP, press CONFIRM

Midas XL4 Automation system

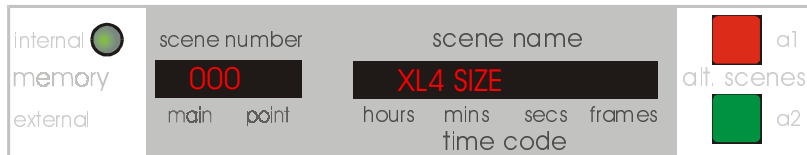

Scroll to XL4 SIZE,  
press CONFIRM

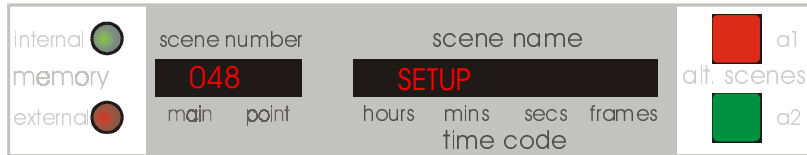

If display prompts 048  
SETUP, press CONFIRM  
If display prompts 0000  
SETUP, scroll to 048, press  
CONFIRM

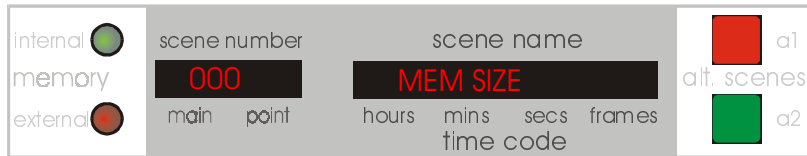

Scroll to MEM SIZE, Press  
CONFIRM

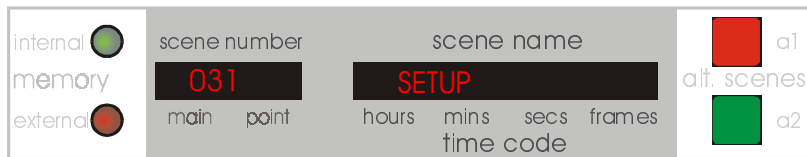

If display prompts 031  
SETUP, press CONFIRM  
If display prompts 000  
SETUP, scroll to 031, press  
CONFIRM

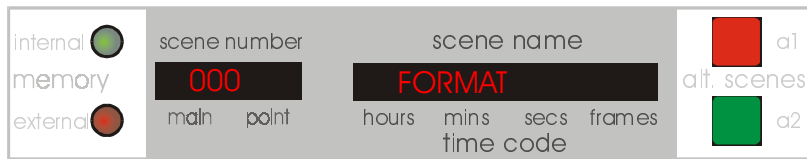

Scroll to FORMAT, Press  
CONFIRM

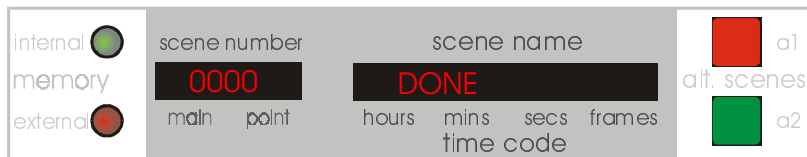

Display prompts WAIT,  
then DONE, then displays  
START

It is advisable to repeat this procedure at the beginning of each new production, first making sure that you have saved your data to your external memory data card.

## Store Menu

There are 2 possible menus available when the 'STORE' button is pressed dependent on whether you are storing a new scene or editing an existing one.

If no scene is present in the location you are trying to store to (displayed in the left hand window) the menu you may access is shown below.

STORE – NEW  
X-FADE

If a scene has previously been stored in the location you are trying to store to (displayed in the left hand window)

Overstore - OVERSTORE  
X FADE  
EXPAND  
INSERT  
DELETE  
EDIT - SC.NAME  
MIDI\_IN ----- Program Number \*\*\*  
Midi CLR  
MIDI OUT ----- 1-Ch No- Prog  
Note on  
Note Off

↓

8-Ch No- Prog  
Note On  
Note Off

9- Exit

### **New scene.**

If the scene number does not yet exist, the display will respond with 'NEW'. To create the scene press 'YES'. The scene will be created and the current status of the console will be stored in it.

The scene number may be adjusted using the jog wheel before pressing 'STORE'. The scene number may be adjusted before or after setting the desired console configuration.

Should 'STORE' be pressed in error, the 'NO' button will exit the procedure without taking any further action.

## Overstoring

If the scene number does exist, the display will respond with '**OVERSTORE**'. To update the scene press '**YES**'. The existing scene will be replaced with the current status of the console.

Pressing '**NO**' will abandon the store procedure without taking any further action.

## X-FADE (Crossfade).

This allows the faders crossfade speed to be adjusted from 0.5 to 10 seconds in 99 equal steps.

The speed is set using the jogwheel, pressing '**YES**' then stores the scene.

**WARNING** When editing the crossfade speed it is important to note that the speed you leave set in the left hand window will be applied to any scene stored or overstored after.

## Expand.

This is used to set the scene number increment value to use the decimal places. This is used when the number of expected scenes is greater than 99. It causes the auto-increment to step in 0.1 steps instead of 1.

## Insert

This option allows extra scenes to be inserted between existing scenes. To insert a new scene dial up the number of the scene that you wish to come **after** the new scene. The scene will be inserted **before** the scene displayed.

The new scene will be given the number of the previous scene plus point five.

Once an extra scene has been added, decimal place numbered scenes will be accessible between the previous scene with a whole number and the next scene with a whole number.

This can occur to two levels, that is scenes may be stored between decimal place numbered scenes using the 'hundredths' digit as well.

## Delete

This option is used to delete the current scene from memory. There is currently no way to restore a scene once it has been deleted, so this function should be used with caution.

## Edit

**EDIT** calls up a further sub-menu for editing facilities.

## Sc. NAME

To enter or edit a scene name, dial up this option and press '**YES**'.

The character in the left hand position of the scene name display may then be adjusted using the jogwheel. When the desired character is visible, press '**YES**' again and the character will be stored. The next character on the right may then be adjusted. Continue until all eight characters have been entered, when the normal system operation will resume. To leave a character as it is, press '**YES**' without moving the jogwheel.



## **MIDI IN**

This function allows you to edit the midi program change that the scene will be recalled by when received. The XL4 will monitor the midi channel set in the CH.MIDI in located in the SYSTEM Menu.

## **MIDI CLR**

This function allows you to clear all the midi information associated with the particular scene you are on.

This function is used to set up a MIDI message which will be transmitted whenever the scene containing the message is recalled.

## **MIDI OUT**

This function allows you to edit the 8 possible midi out messages the console can send out when a scene is recalled.

To program the multiple-midi outputs the following procedure must be followed.

1/ Press *STORE* and scroll the screen using the jogwheel until **EDIT** is seen, press the **YES** button.

2/ Scroll the screen until **MIDIOUT** is seen, press the *YES* button.

3/ You may now select one of the eight midiout messages for editing. This may be done using the jogwheel. When the required message number is displayed in the left hand window press the **YES** button.

4/ In the left hand window the midi channel the message is sent out on will be displayed. This may be changed using the jogwheel, when the required channel is selected press **YES**.

5/ Using the jogwheel you may choose one of the following to edit in the right hand display **NOTEOFF**, **NOTEON**, **PROGRAM** and **CLEAR** when the required parameter is displayed press **YES**. **CLEAR** will delete that particular message from the group sent with that scene change.

6/ The chosen parameter may then be changed using the jogwheel and selected by pressing **YES** when the required value is displayed.

7/ When all the midi out messages have been edited to exit scroll through the message list until **9 EXIT** is displayed and press **YES**.

**NB:** This Function edits the Midi information for the last scene recalled using the Now, Next or Last button.

## **Memory menu**

Memory – Mem Tog

- Internal
- External
- Copy All
- Clear All

### **Mem Tog (Memory Toggle)**

This allows you to swap from the memory you are currently working on to other. For example if you are working on Internal memory mode choosing YES to Mem Tog will switch over to External memory.

### **Internal**

This setting sets the system operation to operate with the central control unit's internal memory.

### **External**

This setting sets the system operation to operate with the RAM card memory .

### **Copy all**

This function copies the data to and from the RAM card.

If **INTERNAL** memory is active, the data will be copied from internal memory to the RAM card.

If **EXTERNAL** memory is active, the data will be copied from the RAM card to the internal memory.

### **Clear all**

This function clears the data in the memory or RAM card.

If **INTERNAL** memory is active, the data will be cleared from internal memory .

If **EXTERNAL** memory is active, the data will be cleared from the RAM card.

### **WARNING!**

Use this function with care! Although future software releases may feature an UNDO function, the current software does not. Once erased there is no way to retrieve the data unless you have saved it to a RAM card which has been kept somewhere safe.

## Alt Scene Buttons A1 and A2

These buttons allow the recall of a scene assigned to the switch with a single button push. To assign a scene to either **ALT1** or **ALT2**, recall the scene you wish to assign. Press the **STORE** button, the right hand screen will now read either **NEW** or **OVERSTORE**. Press the **ALT** button that you wish to assign the scene to, the screen will read **OK**. The scene will now be recalled when ever that **ALT** button is pressed. To place a different scene to the button follow the above procedure and the new scene will automatically be overstored to the **ALT** button pressed.

## Using the system - general hints and tips.

Setting up a console can be a laborious process, setting it up separately for multiple scenes could be worse!

Make use of the facilities to minimise the work. If you have already programmed in a scene which is similar to the one you wish to create, **RECALL** it, make the required alterations then dial up the number of the new scene you wish to create and **STORE** it.

## Backing up.

At the end of a rehearsal session it is good practice to save the data entered to the RAM card. By using three or four RAM cards and rotating them you will always have the last three or four sessions saved ready to be reloaded in an emergency.

