

V4

LIVE PERFORMANCE
CONSOLE



MIDAS

DESIGNED FOR A PURE PERFORMANCE

HISTORY

During its 30 year history, Midas has been producing live sound consoles for the world's most demanding sound engineers and maintains a policy of sonic excellence combined with usability and reliability. To achieve this, the company has always worked closely with leading professional in the field, and in the case of the XL4, Managing Director, Bob Doyle, spent 10 painstaking months finalising the specifications of the console while discussing its concept and aims with world class sound engineers, rental company heads, theatrical production designers and artists. This close involvement of end users enabled Midas to develop a console that would meet the 'real world' needs of the most sophisticated customer, right across the live sound spectrum.

The design brief for the console was to match or exceed the audio performance of the highly acclaimed XL3 and to combine that with a powerful, user-friendly automation system to deliver a no-compromise live performance console ideally suited to the needs of rental companies, touring system operators and high-end theatre installations. The mixing environment was designed to enhance the creativity of the mixing engineer, specifically by automating repetitive tasks allowing the engineer to concentrate on the artistic aspect of the performance.

The XL4 is a 48 channel, 45-buss console that also incorporates an 18 x 8 matrix and eight mute busses. It is designed to offer an uncluttered control surface with the two groups of 24 channels split either side of the central master section, yet it makes effective use of space to offer a reasonably compact footprint. A newly designed mic preamp has been used that further improves on the XL3 circuit to provide increased gain range and lower distortion. This design retains the constant bandwidth topology of the XL3 to ensure amplifier stability along with optimum RF rejection and noise performance at all gain settings. Its EQ section is closely based on that of the acclaimed XL3, though the treble and bass sections have been given extended frequency ranges and may be switched to fully parametric operation.

A separate high impedance input, with level control, is provided for the connection of playback machines and other general-purpose line-level sources and every channel is equipped with a half-normalised, fully balanced, insert send and return (switchable pre or post equaliser) that can be switched in and out from the front panel.

Any channel can be routed to any combination of 42 audio busses comprising 16 mono aux sends, 4 stereo aux sends, 16 audio sub groups and 1 stereo master. Routing can be accessed directly via the front panel or via the on-board automation system. Each input channel has a direct output that can be sourced pre or post equaliser. Excellent metering facilities are provided via 28 high visibility, peak reading bargraph meters that monitor all the main and group outputs but that may be switched globally to monitor pre-fader or post fader sources and may also be used to monitor the 24 aux output levels.

Up to 2000 automation scenes can be stored where a scene includes the channel routing, all major channel control functions and all major output mutes. The 12 motorised master faders (10 acting on inputs and 2 acting on audio groups) controlling VCAs and eight mute masters provide direct control of signal levels within the console and it is possible to import or export automation data for backup or console linking. Input faders can be motorised as an option.

Military spec circuit boards are used throughout, and as with the other consoles in the Midas range, only tight tolerance components are used along with hermetically sealed ALPS pots and 100mm Penny & Giles faders. Like the Midas Heritage series of consoles, the XL4 is manufactured almost entirely by hand in Kidderminster where the engineering and quality control standards demanded of Midas consoles can be maintained. To back up our confidence in the XL4, the console carries a full three year factory warranty, plus the support of a global distributor network.

MIDAS XL4 FEATURES

48 Mic Inputs

The XL4 features a new mic amplifier which further improves on the XL3 design giving increased gain range and lower distortion, whilst retaining the XL3's constant HF bandwidth topology which assures excellent amplifiers stability, RF rejection and noise performance at all gains.

Direct Outputs

Every input module is fitted with a direct output as standard with its own level control and front panel switching which selects the source from post fader, pre fader or pre insert and equaliser.

MIDAS XL4 FEATURES

16 audio sub groups

The 16 main audio groups can be assigned to any of the 8 automute groups and to VCA control from any combination of the 2 motorised grand master faders. A safe switch is again included for each group. The input for the groups is normally derived from the 16 group busses but for monitor applications the fader change over routes the 16 mono aux busses to the group faders.

Line inputs

A separate Hi Z line input with its own dedicated gain control is incorporated which is ideal for playback of recorded material. Global change over from mic (record) to line (playback) is easy because it is under automation control.

Equaliser

The sonic performance of the legendary XL3 equaliser is maintained including the full parametric mid's and traditional Midas bass and treble shelving responses. In addition the treble and bass sections now have an extended frequency range and are switchable to full parametric operation.

Inserts

Each channel has a half normalised fully balanced insert send and return point which can be switched in or out from the front panel and set as either pre or post equaliser.

Input metering

These peak reading meters cover a 60dB range in 3dB steps and can be switched globally to monitor pre fader signals or pre insert and equaliser signals.

Audio busses

Each channel can be routed to any combination of 42 audio busses comprising of 16 mono aux'es, 8 stereo aux'es, 16 stereo groups and 2 stereo masters. All this is switchable on the module front panel but also via the automation control.

VCA and mute busses

Each channel can be controlled by any combination of the 10 motorised VCA master faders and 8 mute masters. Assignment of these busses is again switchable on the module front panel or by the automation control. A safe switch disconnects the channel from all mute groups and an isolate switch removes the channel from all VCA control.

Group aux inputs

An additional 16 inputs with treble and bass equalisation can be routed directly to the groups or via a pan to the masters mix and can be further controlled by assignment to any of the 10 VCA masters.

Master

The stereo master module provides the main left and right console outputs plus 4 more record outputs and a mono output. A solo to master facility is incorporated on the left, right and mono outputs to aid the engineer at sound checks.

Matrix

As standard the 8 matrix outputs derive their signals from the 16 audio groups, left and right masters creating an 18 x 8 matrix. The module also houses the stereo aux masters which have their own outputs at all times but which can be routed directly into the matrix giving an additional 48 x 8 matrix sourcing direct from the input channels.

Output meters

28 peak reading meters (each covering a 60dB range in 3dB steps) are used to monitor all the main outputs i.e. 16 groups, 8 matrix, 2 masters and 2 local outputs. They and can be switched globally to monitor pre fader or post fader signals and can also be used to monitor the 24 aux outputs.

Automutes

The 8 automute masters can be assigned to any input or audio group and act on pre fader and post fader signals. Apart from assignment the operation of these mutes is entirely independent of the automation system.

10 input VCA faders

10 motorised VCA master faders control the channel and aux inputs whilst a further 2 VCA grand master faders control the audio groups. Each VCA master has a solo switch which gives the engineer an opportunity to monitor the signals within the VCA subgroup. Also incorporated is a VCA mute which act on post fader signals only and effectively adds a further 12 automute scenes to the existing dedicated automutes.

Automation

The automation system can store and recall up to 2000 scenes. All channel routing and major functions are automated as well as all major output mutes. The 12 motorised VCA master faders give dynamic control of signal levels within the console and all automation information can be exported or imported in a variety of different mediums for storage or console and system linking.



MIDAS XL402 INPUT POD

The XL402 Input Pod is a comprehensive mic/line input stage featuring switchable phantom power, 20dB pad and the facility to place the mic/line switching under automation control. Separate gain controls are provided for the mic and line inputs. Variable high and low pass filters operate over the ranges 10Hz to 400Hz and 1kHz to 40kHz respectively. A 20-section LED meter monitors the signal level and the phase switch operates on both the mic and line signal paths.



MIDAS XL401 INPUT MODULE

Fed from the XL402 Input Pod, the XL401 Input Module's Direct output can be switched to pick up its signal pre or post the channel insert point. A separate Pre Fade button enables the direct output to be picked up pre or post the channel fader and a rotary control sets the level of the Direct out signal.

The input module incorporates an enhanced MIDAS 4-band equaliser that features two fully parametric mid sections plus variable frequency high and low shelving filters with adjustable frequency ranges (1kHz to 20kHz and 20Hz to 400Hz respectively). Newly added Bell switches and width controls convert the high and low sections from the traditional MIDAS shelving response to fully parametric operation. The two parametric mid range sections can be varied over the ranges 1kHz to 20kHz and 100Hz to 2kHz. The equaliser may be switched pre or post the channel insert point.

Sixteen mono aux controls may be individually assigned to pre or post-fade operation with four further stereo Aux sends. The pre/post switching on the stereo Aux sends change the signal sent to the stereo busses from post fader to pre fader while retaining the post pan stereo image. Aux send on/off switching may be controlled via the automation system.

The module Pan control has a constant power response while a Mute switch mutes the channel at all points except the insert send and pre insert/EQ direct output. An Insert switch connects the input insert return to the input channel either before or after the EQ and is under automation control. The ST switch connects the channel post fader signal to the stereo buss via the Pan control and is also under automation control.





MIDAS XL405 STEREO INPUT POD

The XL405 Stereo Input Pod is a comprehensive mic/line input stage featuring switchable phantom power, a 25dB pad and separate phase switches for the left and right signal paths. A pair of 11-segment meters monitor the signal level in both channel paths.

A switchable Hi Pass filter affects both channels is variable over the ranges 10Hz - 400Hz. A stereo Balance control offers left/right balance adjustment over the range +/-10dB. The XL405 provides a Left and Right Direct output which may be internally linked to be pre or post insert/EQ.

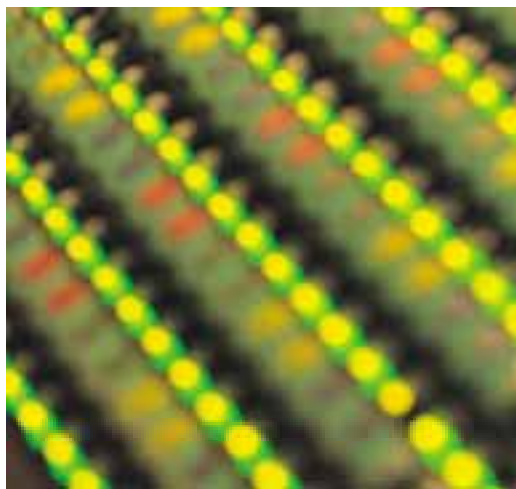

MIDAS XL404 STEREO INPUT MODULE

Fed from the XL405 Input Pod, the XL404 Stereo Input Module incorporates a classic MIDAS 4-band equaliser that features two fully parametric mid sections plus variable frequency high and low shelving filters with adjustable frequency ranges (2kHz to 20kHz and 20Hz to 200Hz respectively). The two fully parametric mid range sections can be varied over the ranges 400Hz to 8kHz and 100Hz to 2kHz. The equaliser may be switched in or out of the signal path manually or via the console automation.

Sixteen mono aux controls may be individually assigned to pre or post-fade operation with four further stereo Aux sends. The pre/post switching on the stereo Aux sends change the signal sent to the stereo busses from post fader to pre fader while retaining the post pan stereo image. Aux send on/off switching may be controlled via the automation system.

Each of the two signal paths has its own constant power response Pan control while a Mute switch mutes the channel at all points except the insert send and pre insert/EQ direct output. An Insert switch connects the input insert return to the input channel either before or after the EQ and is under automation control. The ST switch connects the channel post fader signals to the stereo buss via the Pan control and is also under automation control.





MIDAS XL403 INPUT VCA FADER

Each of the input channels is controlled via a VCA fader providing level adjustment from off to +10dB. An Isolate switch disconnects the channel from the automation scene recall system while a Safe switch disconnects the input channel mute from the eight mute busses.

A large Solo button sends the input channel signal to the PFL mono and AFL stereo busses. If pressed briefly, the switch will latch on or off, but if held for more than one second, latching is disabled and the action becomes momentary.

Ten illuminated Group Assign switches run alongside the fader and provide three distinct functions. Firstly, they assign the post fader signal to the 16 audio groups (in pairs) in conjunction with the pan control. Their second function is to assign the input channel to the 10 moving fader controlled VCA subgroups. Finally, they are also used to assign the input channels to the eight automated mute groups. The function of these switches is selected globally from the central control panel and a lock function is provided making it possible to lock all the input channel group assign switches to prevent inadvertent operation. It is still possible to view the switch status of all three group types when the lock mode is active.





MIDAS XL414 GROUP MODULE

The XL414 Group Module is a flexible but intuitive Group master control strip incorporating two separate rows of controls addressing two adjacent groups. Fader Change Over swaps the mono aux busses with the audio group busses for monitoring applications. There's also an aux return, which can function at mic or line level with individual bass/treble EQ, phantom power switches, gain and pan controls, and switches for Mute Solo and Sub.

Sub disconnects the returns from the stereo master buss and instead routes them to the audio subgroups below, bypassing the pan control.

Grand Master VCA switches A and B assign the audio subgroups to the two Grand Master VCA subgroups. A further bank of Auto Mute Group switches assign the audio subgroups to the eight auto mute groups. Safe switches disconnect individual audio subgroups from the auto mute busses.

A talk switch connects the audio subgroups to the Comms module. When the TALK TO GROUPS switch is on, the Comms module is active and it is possible to route its oscillator, pink noise, external input, talk mic or comms mic to the audio subgroups.

An Ins switch connects the group insert return signals to the audio subgroups while the ST switch sends the post fader audio subgroup signal to the stereo mix buss via the pan control.

The Mute switch, which is under control of the automation and automute group, mutes the audio group at all points other than the insert send.

A large Solo button sends the group signal to the PFL mono and AFL stereo busses. If pressed briefly, the switch will latch on or off, but if held for more than one second, latching is disabled and the action becomes momentary.





MIDAS XL412 OUTPUT METER POD

The XL412 Output Meter Pod provides full metering functions for the 16 output groups, the 16 aux master sends and 16 line level returns. The Pod also provides peak metering of the master stereo, solo, PFL and local buss matrix outputs and the stereo aux send outputs. It employs high visibility, 20-section LED meters and a master Global Meter Changeover button on the Comms module provides two distinct metering modes (Output level or buss amplifier level). The Aux switch changes the meter source for both meters from group outputs to aux send while the Return switch changes the function of both meters so that they monitor the post fade line return signals. If the Aux switch is not activated, the meters revert to monitoring the audio Group outputs regardless of the Return switch status. The 20-segment precision LED meters normally monitor the peak levels of the group, aux or returns as selected. When the Global Meter Changeover switch on the Comms module is activated, the meters monitor the group buss, aux buss or line level returns as selected.

The Master meters normally track the stereo left and right output levels, but when the Global Meter Changeover function is active, they instead monitor the left and right buss amplifier levels. The Solo meters monitor either the peak stereo AFL levels or the PFL and local output levels as selected via the PFL Monitor switch on the Comms module.

Individual changeover switches for the left and right meters are located above each pair of Matrix meters enabling the meters to monitor the stereo aux send outputs in place of the matrix outputs. The meters normally follow either the stereo aux outputs or the matrix outputs as selected unless the Global Meter Changeover is active, in which case the meters monitor the matrix buss or stereo buss amplifier levels.





MIDAS XL413 MASTER VCA FADER

The XL413 Master Fader section provides moving fader control of the 10 VCA subgroups plus the two Grand Masters with solo and metering facilities. Isolate switches isolate the corresponding Group or Grand Master A/B VCA from the automation system. VCA Mute switches mute any post fade signal assigned to corresponding Group/Grand Master A/B.

The VCA Solo switches make it possible to monitor the corresponding VCA subgroups or Grand Master A/B by creating a corresponding Audio subgroup on the stereo AFL busses. All input channels and line returns assigned to a VCA subgroup will be summed onto the solo busses when the VCA Solo is active. If pressed briefly, the switch will latch on or off, but if held for more than one second, latching is disabled and the action becomes momentary.



MIDAS XL421 MASTER MODULE

The XL421 Master Module provides fader control over the main mix outputs as well as two separate recording outputs. Record 1 and 2 are stereo and have a single level control each as well as a mute button. A 10 section LED meter shows the peak level of whichever channel is currently loudest.

A large Mute All button mutes all the console outputs, effectively turning the console off. A Solo In Place switch the mono, left and right master signals (pre-insert) and replaces them with the signal on the stereo AFL solo busses. The master matrix feeds are not affected by this operation.

The mono output, which has its own Mute button, is controlled by an independent fader and is monitored post-fader by a high resolution 20-section LED peak level meter.

When the Global Meter Changeover switch is active, the meter monitors the output of the mono buss summing amplifier. The VCA fader switch links the mono fader to the stereo master fader so that they track together.

A Solo button is provided that features the same momentary or latching action as other Solo buttons on the console while the mono Ins switch feeds the mono insert return into the mono mix.

A further Aux I/P Mute button mutes all the group module aux line returns.

The main stereo fader has separate Mute and Solo buttons for each channel along with a stereo balance control that provides from off to +3dB.

A Matrix Send Pre button feeds a pre fader/pre-insert signal from the stereo busses to the matrix modules. Normally the matrix modules is fed from the post fade signal.





MIDAS XL431 COMMUNICATION MODULE

The XL431 Communication Module, which is Clearcom compatible, provides central control over the console's Talkback functions, test oscillator, Auto Mute Group master switching and Solo/PFL mode selection. It also allows control over the local output level and headphone output level as well as headphone muting and Solo On/Clear switching. The internal oscillator section can be swept from 100Hz to 10kHz as well as Pink noise and the oscillator output may be switched to the talk system.

Six separate Talk buttons allow the talk signal to feed any combination of the auxes, groups, matrix, mono, left and right busses. A balanced talk mic input is fitted along with a talk button that automatically dims the local outputs by 20dB to prevent howlround. A Link switch connects the talk system into the comms system such that the talk mic can send and the headphones and local output can receive 'Clearcom' signals as well as the headset.

A large illuminated Call button at the top of the module shows when a Clearcom signal is expected and also sends a DC pulse when pressed to illuminate the Call lamps on connected Clearcom devices.

Eight large illuminated Auto Mute Group Master switches function mute any input channel or audio group assigned to the corresponding mute group.

A Solo Add mode switch enables multiple sources to be solo'd simultaneously while the PFL Monitor switch sends the mono PFL solo buss signal to the headphones and local outputs instead of the stereo AFL solo buss signal.

The global Meter Changeover switch affects all the meters on the console except the comms and record meters. Normally, the meters monitor pre-fade on the input channels and post-fade on all other signals, but when this switch is active, the meters monitor the input amplifier or buss amplifier signals as appropriate.

The local output level rotary control and the phones output fader may have their functions swapped via the Fader C/O switch. The corresponding mute switches are also exchanged in this mode.

A large Headphone Mute switch mutes the phones outputs while the Solo On/Clear switch illuminates when any solo switch other than a Master Solo switch is active and, when pressed, it clears any active solo switches (other than master solo switches).





MIDAS XL441 MATRIX MODULE

The XL4 features a clearly presented and flexible matrix control system. The eight matrix outputs may be derived from the 16 audio groups as well as the left and right mix signals, providing a full 18 x 18 matrix. This module also includes the Stereo Aux Masters. These have their own outputs at all times, but may also be routed directly into the matrix to provide an additional 48 x 8 matrix sourced directly from the input channels.

The XL441 Matrix Module is mainly occupied by two rows of 16 individual Mix controls which adjust the audio subgroup levels over the range +6dB to off. When the Changeover switch on the Group module is active, the mono aux buss feeds the matrix in place of the audio sub group.

The stereo Aux Master control at the top of module sets the stereo aux output level while the adjacent MTX switch directs the pre-fader stereo aux buss signals to the matrix mix for monitoring applications.

A stereo Aux Mute switch is provided along with a stereo aux Solo switch that sends the stereo aux signals to the PFL mono and AFL stereo busses. If pressed briefly, the switch will latch on or off, but if held for more than one second, latching is disabled and the action becomes momentary.

A Global Pre On switch beneath the Mix control section changes the audio subgroup signals routed via the matrix mix controls from post-fader to pre-fader.

Master Left and Right controls enable the master left and right signals to be added to the Matrix mix.

A Talk button connects the matrix busses to the comms module, and when the Talk to Matrix switch on the Comms modules is active, it is possible to route pink noise, the tone oscillator, the talk mic or an external input to the matrix mix. The Ins switches connect the matrix insert return signals to the matrix mixes while the matrix Mute switches (which are under automation control) mute the matrix outputs but not the insert sends.

The matrix Solo switch sends the signal to the PFL mono and AFL stereo busses. If pressed briefly, the switch will latch on or off, but if held for more than one second, latching is disabled and the action becomes momentary. Note that these switches do not operate when the console is in Solo In Place mode. This is a safety feature to prevent the matrix outputs being inadvertently routed back to their own inputs via the master matrix feed.





MIDAS XL443 AUTOMATION CONTROL

The MIDAS XL4 utilises specially developed microprocessor technology, enabling it to deliver an unprecedented feature set for a live console, whilst at the same time retaining the look, feel and ease of use of a traditional console. The rate at which scenes can be changed is a concern to many users but the XL443 is capable of updating itself over fifty times a second making recall virtually instantaneous (around 20mS). Furthermore, because the MIDAS XL4 is a 'computer assisted' console, all its audio functions may be controlled without the central control CPU when necessary.

The CPU system was developed in conjunction with console automation specialists OUTBOARD ELECTRONICS Ltd where each input channel has its own microprocessor. Two further microprocessors handle the VCA master section and the central control section. This means that a standard 48 input console employs no fewer than 50 microprocessors providing both high speed operation and a high degree of protection. In the event that a microprocessor should fail, the others will continue to operate normally. Furthermore, the software comprises a number of smaller programs which are easier to test and debug, minimising the chances of software problems.

Key functions, such as MUTE switches, whilst they can be overridden by microprocessor control, will work without the intervention of a microprocessor. Reliability in a live performance environment is paramount to the MIDAS philosophy.





THE CENTRAL CONTROL UNIT

The MIDAS XL4 Automation is controlled from the Central Control section to the right of the VCA Master faders. Control of the system is via eight buttons and a 'jogwheel' with two displays (a four character 'scene number' display and an eight character 'scene name' display) providing the user feedback. The main 1 Meg of internal memory is battery backed up and may also be downloaded on to a memory card.

At the top of the panel are the 'AUDIO', 'MUTE', 'VCA' & 'LOCK' switches which determine the operating mode of the input fader.

With the 'AUDIO' mode enabled, the fader bay switch bank controls the audio group routing. With the 'MUTE' mode enabled, the fader bay switch bank controls the automute assignments while with the 'VCA' mode enabled, it controls the VCA assignments. 'LOCK' allows the three operating modes to be called up, (allowing the state of the switches to be seen), but changes are not permitted. On power up, all functions which modify the stored data are disabled until the system has been unlocked using a user password.

The automation follows a Scene-based paradigm and when storing a new scene, the system will inform the user whether the scene is being written into an empty location or overwriting an existing scene. Recalling scenes is achieved very simply using the 'LAST', 'NOW' and 'NEXT' buttons, and also using the jogwheel. MIDI scene recall is also possible.

Pressing the 'NEXT' button steps to the next scene number in memory and recalls it to the console. After the last scene has been recalled, pressing 'NEXT' displays 'END', indicating that no other operation will occur.

Pressing 'LAST' moves to the previous scene and recalls it to the console. Up to 2000 automation scenes can be stored where a scene includes the channel routing, all major channel control functions and all major output mutes. When the system is locked, the jogwheel can only access the numbers of scenes that exist in memory - no operations other than recall are available while the system is locked.

The console also has a very practical MIDI implementation, enabling scenes to be recalled via MIDI Program change messages. MIDI Program changes may be mapped to the scene numbers required be recalled and the MIDI channel may be set in the System menu.

Using the MIDI Out function, it is possible to set up eight MIDI Out messages to be automatically transmitted when a scene is recalled. These may be used for such tasks as switching patches on externally connected MIDI controlled effects units.



XL432 BROADCAST COMMS MODULE



over the range + 6dB to off. When in Link mode, the Comms On switch feeds the talk mic into the comms system using the side tone cancel circuit to prevent howlround.

Talk External provides continuous adjustment of the talk mic level feeding the external talk output while the Talk External switch connects the talk mic to the talk external output while dimming the local monitor outputs by 20dB to prevent howlround

Talk Internal adjusts the talk mic level feeding the internal talk system while the Talk Internal switch routes the talk mic to the internal talk system and dims the local monitor outputs by 20dB. Note that none of the talk internal or external controls affect signals sent to the comms system when in LINK mode.

Eight large Auto mute Master switches activate the mute circuits on any appropriately mute group, assigned input channel or audio group. The module includes a comprehensive solo PFL section where selecting Solo Add mode enables multiple channels simultaneous access to the Solo busses. With Solo Add mode off, pressing any Solo switch will cancel any other active Solos (except for the Master Solo switches - see XL421 Master Module).

PFL to Monitor connects the PFL signals to the monitor outputs in place of the 2-track return or master left and right signals whenever a Solo is active. This switch overrides the Solo To Monitor switch directly below it. Unless overridden by the PFL To Monitor switch, the Solo To Monitor switch connects the Solo/AFL signals to the monitor system outputs in place of the 2-track return or master left and right signals whenever a Solo is active.

The large Solo / Clear button illuminates when any Solo switch (except a master Solo switch) is active. When pressed, it clears any active Solo switches (except master Solo switches).



The Global Meter Change Over switch changes the function of all the console meters (except the Comms meters and the Record meters) from their default of monitoring pre-fader levels on the input channels and post-fader levels for all other signals. When Global Meter Change Over is active, the meters instead monitor levels at the input amplifiers or buss amplifiers (as appropriate) for all signals. The 2-Track Return Change Over switch sends the 2-track input signals to the monitor system outputs in place of the master left and right signals.

An Intercom Level control adjusts the level of the Clearcom signal levels fed into the headphones and PFL speaker output while External 1 controls the level of signals fed into External input 1. Signals from the PFL busses are adjusted using the PFL Level control and the External 2 control adjusts the level of signals fed into External input 2. PFL LS Level provides continuous adjustment of signals sent to the PFL speaker output and Headphone Source Change Over sends PFL signals to the headphone amplifier in place of the monitor signals. The headphone amplifier is fitted with a variable level control.

An A/B Speaker Change Over switch routes the stereo monitor signals from the 'A' speaker outputs to the 'B' speaker outputs.

The output to the local monitoring system is controlled by the Local LS Level knob, which provides continuous adjustment of signals sent to the 'A' or 'B' monitor speaker outputs. Phase reverses the phase of the left hand monitor signal and Mono sums the left and right monitor signals with a 4.5dB summing loss.

The left/right Crossover switch routes the left hand monitor signal into the right channel output speakers and the right hand monitor signal into the left channel output speakers. A -20dB Dim switch with indicator dims the monitor speaker outputs by 20dB and illuminates to show that the talk system has dimmed the monitor speaker level (to prevent howl round).

Left To Both and Right To Both switches enable either output source to feed both channels while separate Mute Left and Mute Right switches make it possible to mute either output independently.



XL4 INPUT MODULE BLOCK DIAGRAM

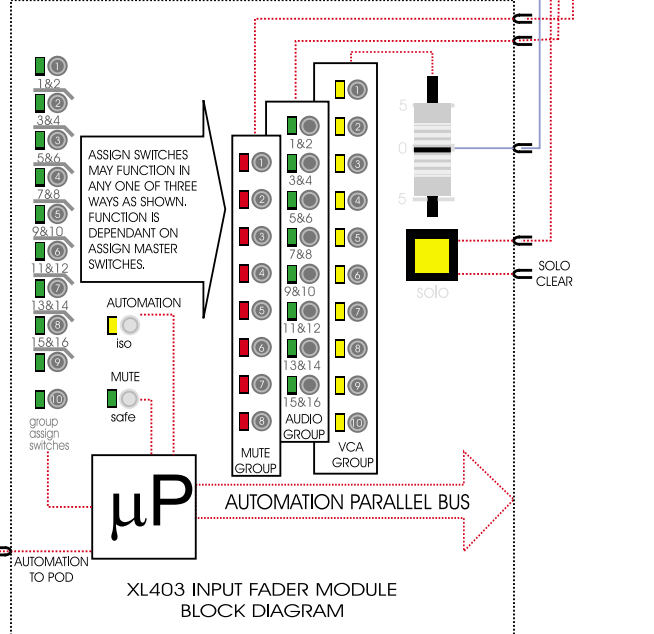
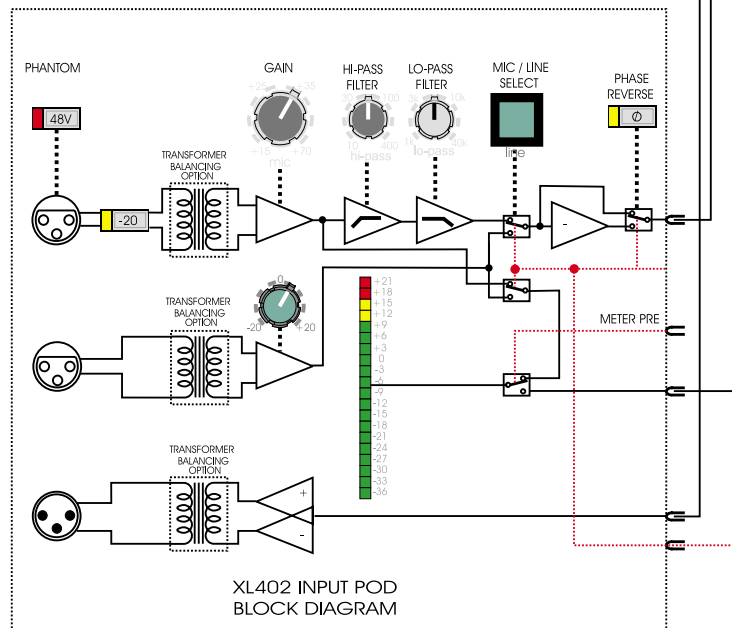
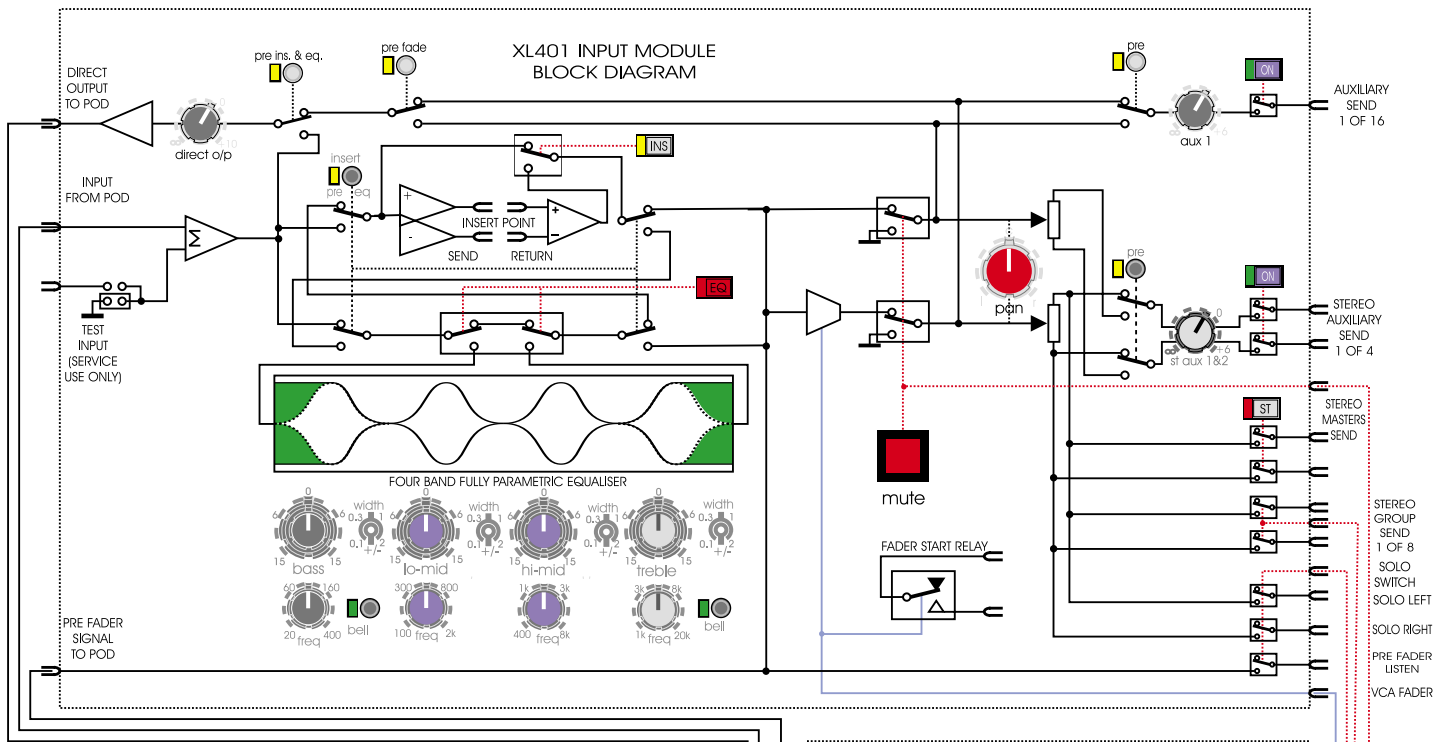

SIGNAL PATH KEY

- = ANALOGUE SIGNALS
- = D.C. SIGNALS
- = AUTOMATION SIGNALS

XL411 GROUP MODULE BLOCK DIAGRAM

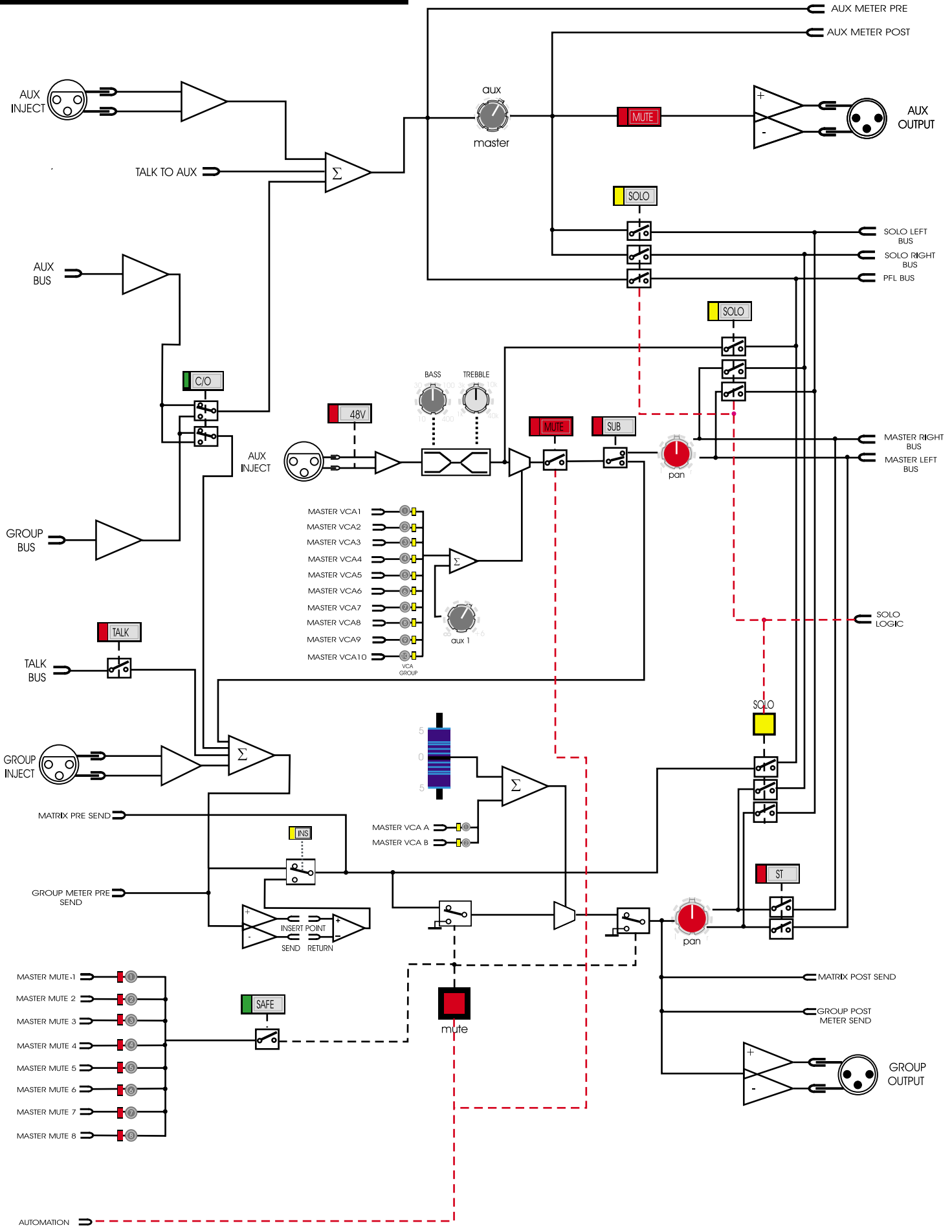

XL421 MASTERS MODULE BLOCK DIAGRAM

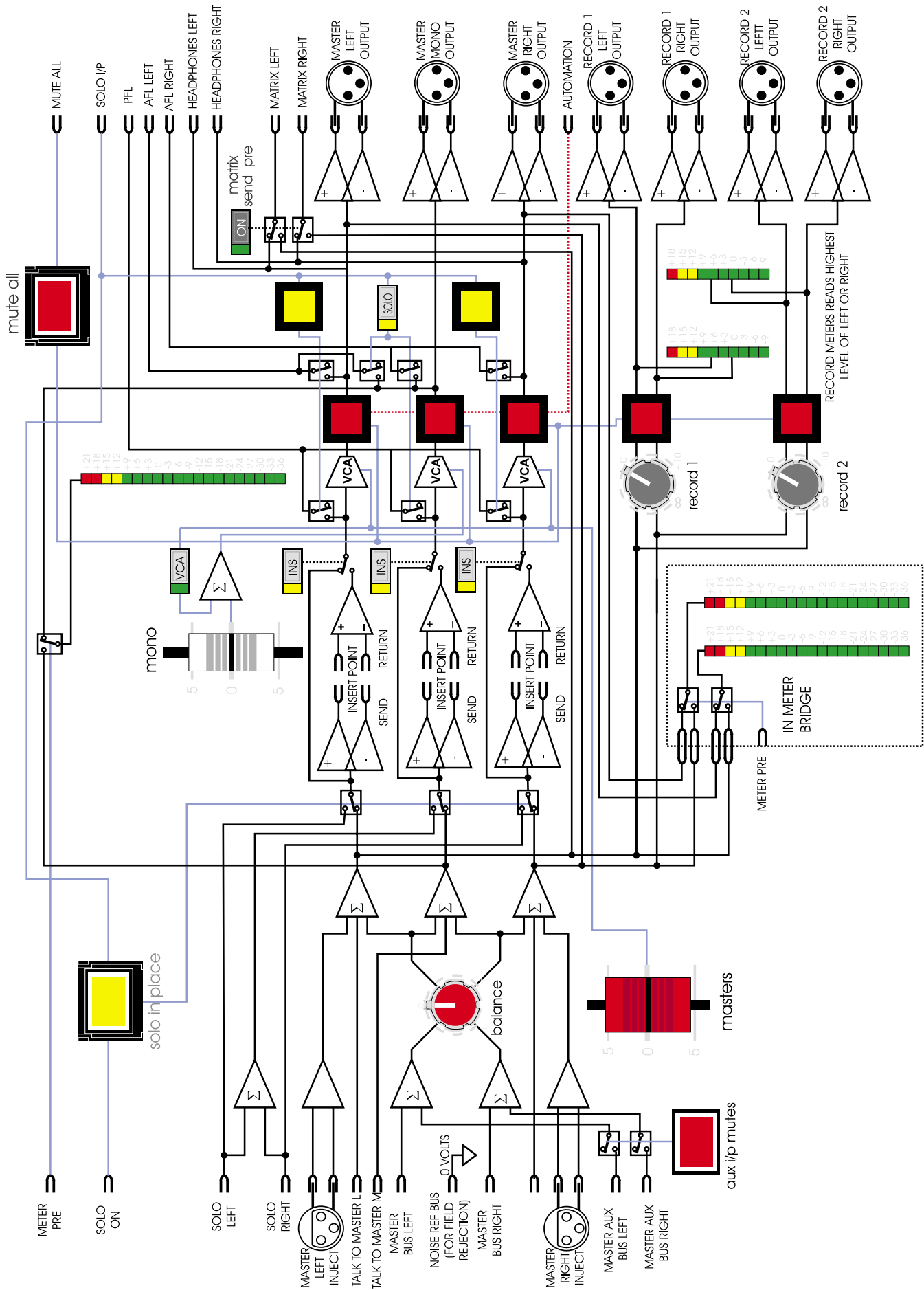

XL431 COMMS MODULE BLOCK DIAGRAM

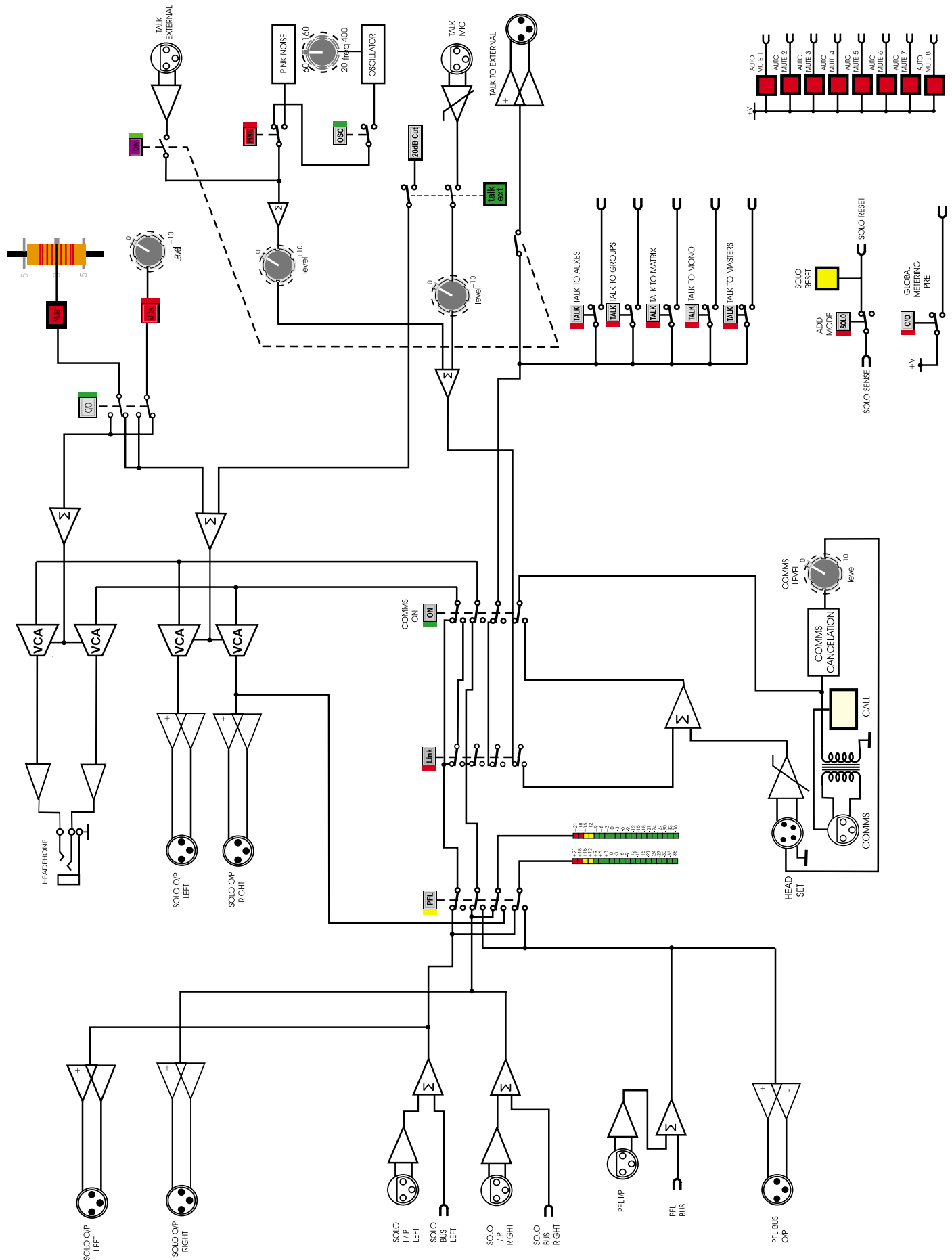

XL441 MATRIX MODULE BLOCK DIAGRAM

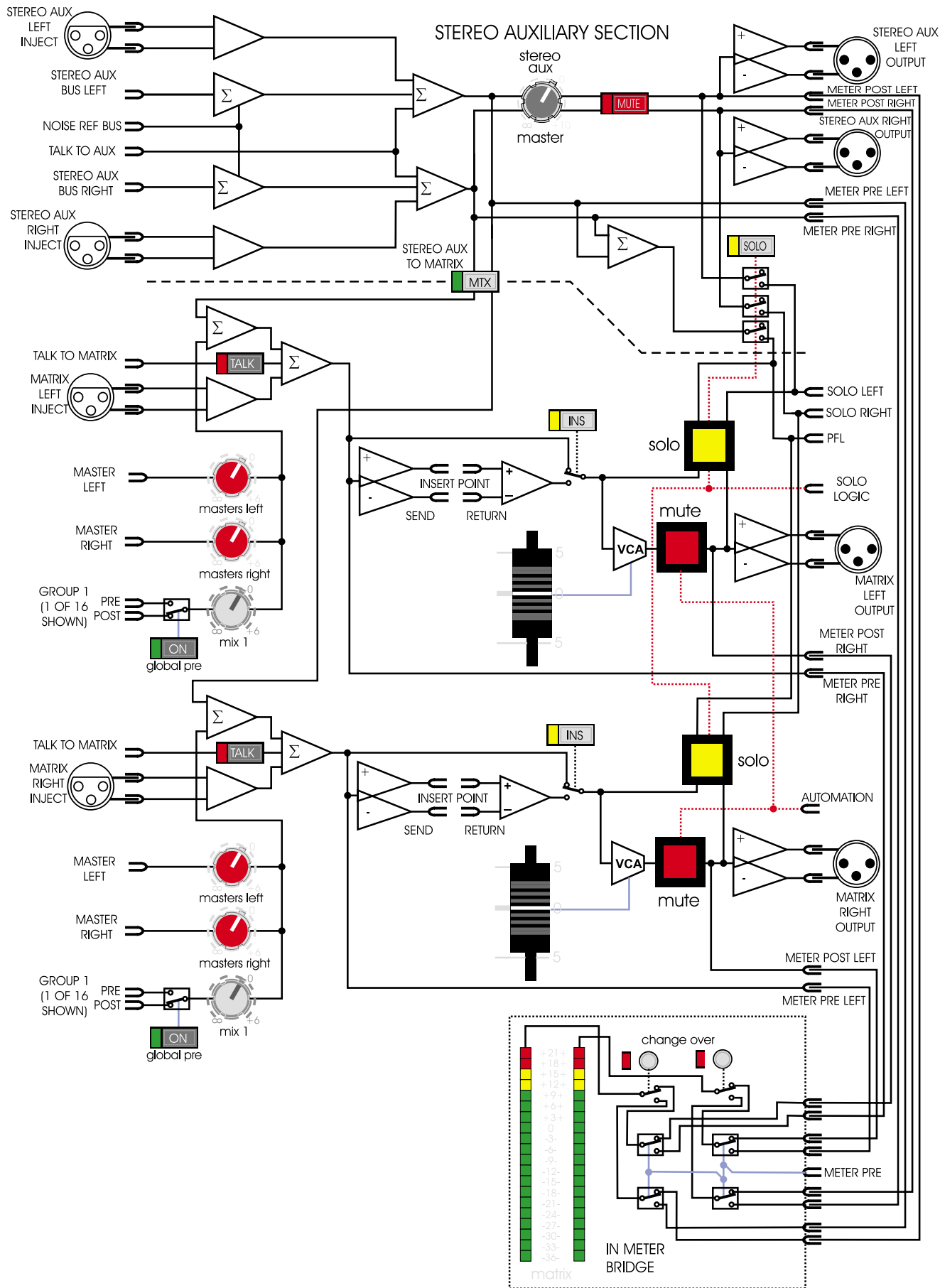

XL432 BROADCAST COMMS MODULE BLOCK DIAGRAM

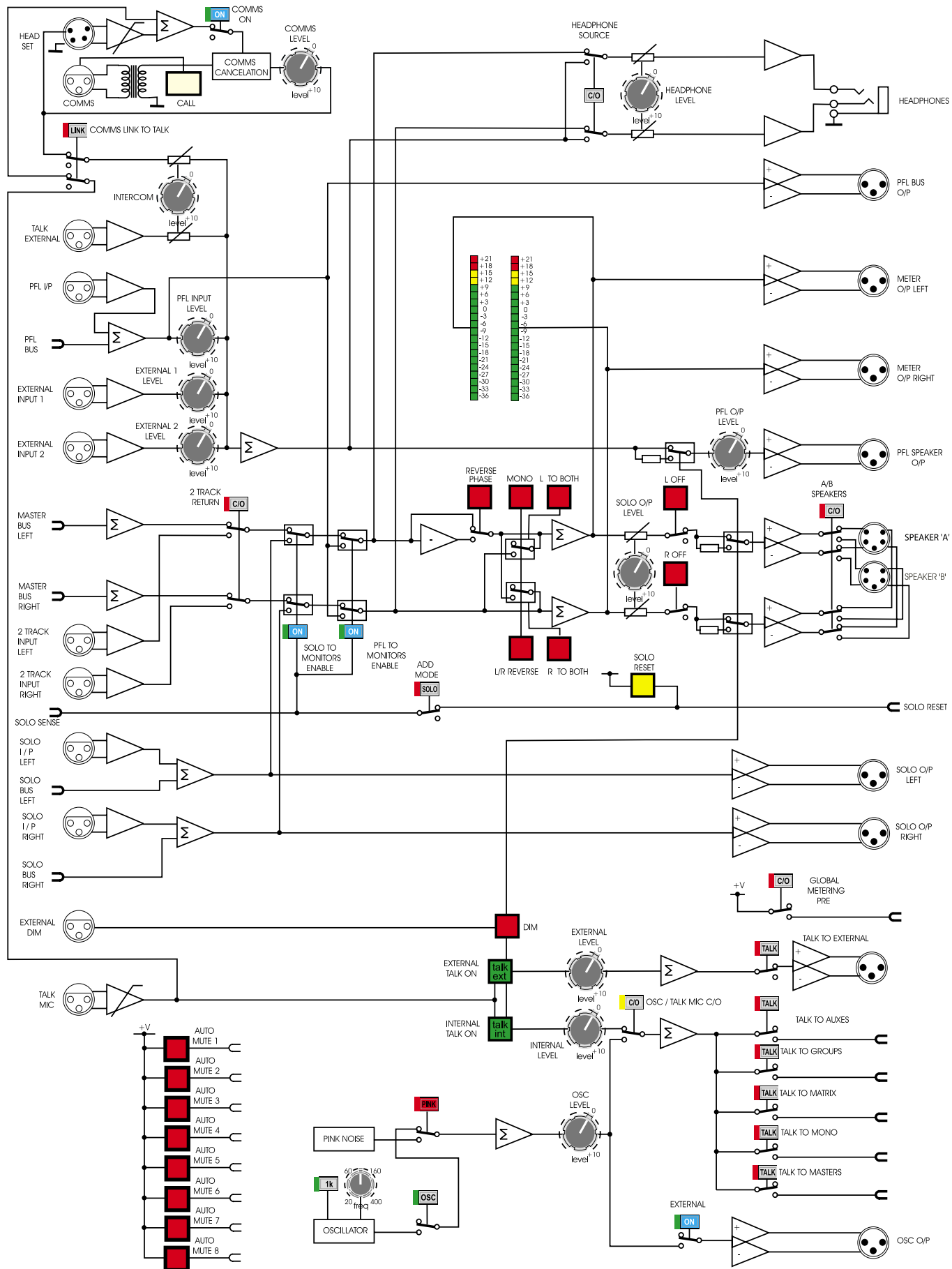

XL4 TECHNICAL SPECIFICATIONS

Input Impedance	Mic	2K Balanced
	Line	20K Balanced
Input Gain (all faders at 0dB)	Mic	Continuously variable from + 15dB to + 70dB
	Mic + Pad	Continuously variable from - 5dB to + 50dB
	Channel Line Input	Continuously variable from - 20dB to + 20dB
	All other Line Inputs	0dB
Maximum Input Level	Mic	+ 6dBu
	Mic + Pad	+ 26dBu
	Channel Line inputs	+ 26dBu
	All other Line Inputs	+ 21dBu
CMR at 1KHz	Mic (gain + 60dB)	> 70dB
	Mic + Pad (gain + 40dB)	> 50dB
	Line	> 60dB
Frequency Response (20 to 20KHz)	Mic to Mix (gain + 60dB)	+ 0dB to - 1dB
	Line to Mix	0dB to - 1dB
Noise (20 to 20KHz)	Mic EIN ref. 150 Ohms (gain + 60dB)	- 129dBu
	Line EIN ref. 150 Ohms (gain + 10dB)	- 100dBu
System Noise (20 to 20KHz)	Summing Noise (12 channels routed with faders down)	- 86dB
	Line to Mix Noise (12 channels routed at 0dB, pan centre)	- 81dB
Summing Noise	(48 channels routed with faders down)	- 80dB
	Line to Mix Noise (48 channels routed at 0dB, pan centre)	- 75dB
Distortion at 1KHz	Mic to Mix (+ 60dB gain, 0dBu output)	< 0.03%
	Line to Mix (0dBu)	< 0.03%
Crosstalk at 1 KHz	Channel to Channel	< - 100dB
	Mix to Mix	< - 90dB
	Channel to Mix	< - 90dB
	Maximum Fader attenuation	> 90dB
Output Impedance	All Line Outputs	50 Ohms Balanced Source to drive > 600 Ohms
	Headphones	To drive > 8 Ohms Unbalanced
	Comms (Bi - directional)	600 Ohms Nominal Unbalanced
Maximum Output Level	All Line Outputs	+ 21dBu
	Headphones	+ 21dBu (8W into 8 Ohms)
	Comms (Bi - directional)	10dBu

Nominal Signal Level	Mic	- 70dBu to + 5dBu
	Channel Line Inputs	- 20dBu to + 5dBu
	All other Line Inputs and outputs	0dBu
	Headphones	+ 10dBu
	Comms	- 20dBu
	Comms and Talk Mic	- 50dBu to - 20dBu (auto gain)
<hr/>		
Headroom at all stages	Comms, Talk and Headphone	> 10dB
	All other signals	> 20dB Metering Type 20 led peak reading
	Range	- 36dBu to + 21dBu
	Colour Green	Up to + 9dBu Normal signal
	Colour Yellow	+ 12dBu to + 15dBu High signal
	Colour Red	Over + 18dBu Signal Too High
Quantity	77 (Monitoring all main Inputs and outputs)	
<hr/>		
Equaliser	Low pass slope	12dB / Oct.
	Low pass frequency	Continuously variable -3dB point from 1K to 40K
	Hi pass slope	12dB / Oct.
	Hi pass frequency	Continuously variable 3dB point from 10Hz to 400Hz
	Treble Gain	Continuously variable + 15 dB to - 15 dB Centre detent 0dB
	Treble Shelving Freq	Continuously variable - 3dB point from 1K to 20K
	Treble Bell Freq	Continuously variable centre from 1K to 20K
	Treble Bell Bandwidth	Continuously variable 0.1 Oct. to 2 Oct. Centre detent 0.5 Oct.
	Hi Mid Gain	Continuously variable + 15 dB to - 15 dB Centre detent 0dB
	Hi Mid Freq	Continuously variable centre from 400Hz to 8K
	Hi Mid Bandwidth	Continuously variable 0.1 Oct. to 2 Oct. Centre detent 0.5 Oct.
	Lo Mid Gain	Continuously variable + 15 dB to - 15 dB Centre detent 0dB
	Lo Mid Freq.	Continuously variable centre from 100Hz to 2K
	Lo Mid Bandwidth	Continuously variable 0.1 Oct. to 2 Oct. Centre detent 0.5 Oct.
	Bass Gain	Continuously variable + 15 dB to - 15 dB Centre detent 0dB
	Bass Shelving Freq	Continuously variable 3dB point from 20Hz to 400Hz
Bass Bell Freq.	Continuously variable centre from 20Hz to 400Hz	
Bass Bell Bandwidth	Continuously variable 0.1 Oct. to 2 Oct. Centre detent 0.5 Oct.	

XL490 POWER SUPPLY



Front panel	Width	482mm/19"
	Width	427mm/16.81"
	Depth	460mm/18.11" (incl. handles)
	Height	135mm/5.31" (incl. feet)
	Weight	20kg/44.09lbs

Specs:	Input voltage range	90-132 and 180 to 250vac
	Input Range Selection	Automatic
	Input Frequency	47-63Hz
	Input Rating (fully loaded)	1400W
	Input Current (fully loaded @110v)	13A
	Input Current (fully loaded @220v)	6.5A
	Input Surge	136A pk

XL4 SPECIFICATION OVERVIEW AND STATISTICS

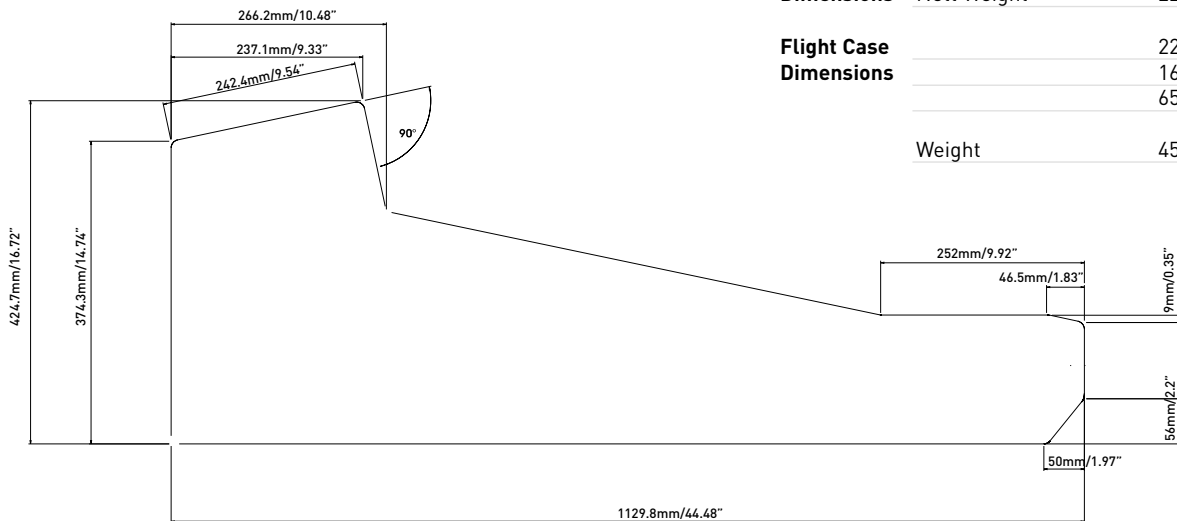

Console Dimensions	Depth	1129.8mm/44.48"
	Nett Weight	229kg / 505lb

Flight Case Dimensions		2260mm/88.98" (width)
		1680mm/66.14" (depth)
		650mm/25.59" (height)

Weight	450kg/992lbs (approx)
---------------	-----------------------

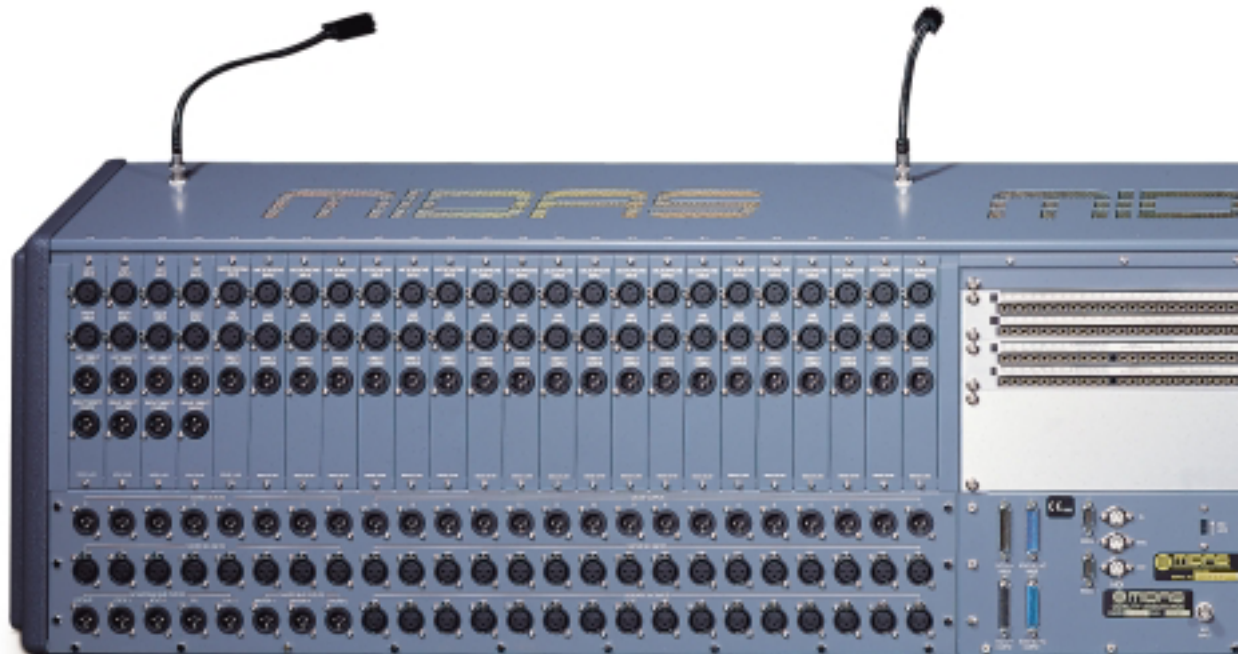

2176 mm/85.67"

The XL4 is a 45 buss console with an additional 18 X 8 output matrix. The busses are as follows:-

16 mono aux = 16
16 audio sub groups = 16
4 stereo aux = 8
1 stereo master = 2
1 stereo AFL = 2
1 mono PFL = 1
TOTAL = 45

The XL4 has 8 automute sub groups, 10 input channel VCA sub groups which include VCA sub group muting and 2 grand master VCA sub groups with VCA sub group muting.

The XL4 has 48 input channels with separate line and mic inputs plus an additional 16 aux line returns.

The XL4 has a total XLR input count of 171 as follows:-

48 channel line inputs
48 channel mic inputs
24 aux bus inject inputs
16 audio group bus inject inputs
16 aux line returns inputs
8 matrix bus inject inputs
3 solo bus inject inputs
2 master bus inject inputs
1 comms mic input (headset)
1 comms input (and output)
1 talk mic input
1 talk bus inject input
1 midi input

The XL4 has a total XLR output count of 111 as follows:-

48 input channel direct outputs
24 aux outputs
16 audio group outputs
8 matrix outputs
4 record outputs
3 master outputs
3 solo outputs
2 local outputs
2 midi outputs
1 talk output

The XL4 has a total bantam jack field count of 158 as follows:-

56 input channel insert sends
(8 spare for stereo module up grades)
56 input channel insert returns
(8 spare for stereo module up grades)
16 audio group insert sends
16 audio group insert returns
8 matrix insert sends
8 matrix returns
8 parallel links (2 sets of 4)
3 master insert sends
3 master insert returns

The XL4 has 12 motorised moving faders for the VCA masters.

The XL4 has a total of 2539 automated switch functions as follows:-

960 input channel aux send on off switches
480 input channel VCA sub group assign switches
384 input channel audio sub group assign switches
384 input channel mute sub group assign switches
48 input channel EQ on off switches
48 input channel stereo master on off switches
48 input channel phase switches
48 input channel insert on off switches
48 input channel mic line switches
48 input channel mute switches
16 audio sub group mute switches
16 aux line return mute switches
8 matrix mute switches
3 master mute switches

The XL4 has a total of 77 peak program meters with 20 LED segments each and monitoring 282 signal points within the console.

Please note: XL4s are wired to take stereo channels in positions 17-24 and 41-48 as standard



KLARK TEKNIK GROUP



KLARK TEKNIK
SIGNAL PROCESSING BY DEFINITION



MIDAS
DESIGNED FOR A PURE PERFORMANCE

Since 1974 the Klark Teknik brand has been synonymous with the single-minded pursuit of excellence in professional signal processing. Recognised worldwide for their innovation, Klark Teknik have introduced many ground-breaking designs including the world's first digital delay and reverberation units. Their pioneering tradition continues to this day, with the recent introduction of the DN9848 digital loudspeaker processor and DN1248 active splitter systems. With these units and others, Klark Teknik have once again defined the standards to which others aspire. Although famous for their equalisation and analysis units, the range today also encompasses dynamic processors, digital and analogue system controllers, analogue utility units, multi-purpose processors and active DI boxes. All Klark Teknik units are designed, engineered and tested to the most stringent standards, providing the longest possible working life in the field with the lowest downtime, and the highest residual values of any comparable product.



Since their original genesis in the late 1960s, Midas consoles have remained the premier choice of discerning audio professionals all over the world. Their unique combination of engineering quality, audio performance, real-world reliability and global acceptance makes them the definitive article in the world of professional audio. The legendary XL3 brought Midas back into the big league in 1990, and was later followed by the XL200, the XL250 and the awesome XL4 which remains the flagship of the range. The introduction of the Heritage range of consoles further consolidated Midas' global domination of the industry, with the award-winning Heritage 3000 becoming the most popular console the company has ever manufactured. Now, the Venice compact console and the fabulous Legend range bring the great sound of Midas to a whole new group of users, whilst the striking new Broadcast 2000 console brings Midas' unrivalled expertise to the world of broadcast.

Klark Teknik Group

Klark Teknik Building, Walter Nash Road, Kildeminster, Worcestershire, DY11 7HJ, England.
Tel: +44 (0) (1562) 741515 Fax: +44 (0) (1562) 745371 www.klarkteknik.com www.midasconsoles.com

Midas Distributors

Country	Address	Telephone	Fax
United States of America	12000 Portland Avenue South, Bumsville, MN 55337	+ 1 952 884 4051	+ 1 952 884 0043
Australia	Unit 24, Block C, Slough Avenue, Slough Business Park, Silverwater, NSW 2141	+ 61 296483455	+ 61 296485585
France	Parc de Courcerin, Allee Lech Wabsa, Lognes, F77322 Mame La Vallee, Cedex 2	+ 33 164800090	+ 33 160065103
Germany	Hirschberger Ring 45, Postfach 0254, D-94315 Straubing	+ 49 94217060	+ 49 9421706357
Hong Kong	Unit E & F, 21/F Luk Hop Ind Building, 8 Luk Hop St, San Po Kong, Kowloon	+ 852 23513628	+ 852 23513329
Japan	2-5-6 Izumi Sughamaku, Tokyo 168	+ 81 333257900	+ 81 333257789
Mexico	Parque Chapultepec 66-201, Col. El Parque, Naucalpan de Juarez, EDO. De Mexico 53390	+ 52 5508 6818	+ 52 5358 5588